

DRONE PILOT (JUNIOR)

NSQF LEVEL - 3

TRADE THEORY

SECTOR: AEROSPACE & AVIATION

(As per revised syllabus July 2022 - 1200 of hrs)



Directorate General of Training

DIRECTORATE GENERAL OF TRAINING
MINISTRY OF SKILL DEVELOPMENT & ENTREPRENEURSHIP
GOVERNMENT OF INDIA



**NATIONAL INSTRUCTIONAL
MEDIA INSTITUTE, CHENNAI**

Post Box No. 3142, CTI Campus, Guindy, Chennai - 600 032

Sector : Aerospace & Aviation

Duration : 6 Months

Trades : Drone Pilot (Junior) - Trade Theory - NSQF Level - 3 (Revised 2022)

Developed & Published by



National Instructional Media Institute

Post Box No.3142

Guindy, Chennai - 600 032

INDIA

Email: chennai-nimi@nic.in

Website: www.nimi.gov.in

Copyright © 2023 National Instructional Media Institute, Chennai

First Edition: January 2023

Copies: 500

Rs.130/-

All rights reserved.

No part of this publication can be reproduced or transmitted in any form or by any means, electronic or mechanical, including photocopy, recording or any information storage and retrieval system, without permission in writing from the National Instructional Media Institute, Chennai.

FOREWORD

The Government of India has set an ambitious target of imparting skills to 30 crores people, one out of every four Indians, by 2020 to help them secure jobs as part of the National Skills Development Policy. Industrial Training Institutes (ITIs) play a vital role in this process especially in terms of providing skilled manpower. Keeping this in mind, and for providing the current industry relevant skill training to Trainees, ITI syllabus has been recently updated with the help of Media Development Committee members of various stakeholders viz. Industries, Entrepreneurs, Academicians and representatives from ITIs.

The National Instructional Media Institute (NIMI), Chennai, has now come up with instructional material to suit the revised curriculum for **Drone Pilot (Junior) - Trade Theory- NSQF Level - 3 (Revised 2022) in Aerospace & Aviation Sector under Six Months pattern**. The NSQF Level - 3 (Revised 2022) Trade Theory will help the trainees to get an international equivalency standard where their skill proficiency and competency will be duly recognized across the globe and this will also increase the scope of recognition of prior learning. NSQF Level - 3 (Revised 2022) trainees will also get the opportunities to promote life long learning and skill development. I have no doubt that with NSQF Level - 3 (Revised 2022) the trainers and trainees of ITIs, and all stakeholders will derive maximum benefits from these Instructional Media Packages IMPs and that NIMI's effort will go a long way in improving the quality of Vocational training in the country.

The Executive Director & Staff of NIMI and members of Media Development Committee deserve appreciation for their contribution in bringing out this publication.

Jai Hind

Addl. Secretary / Director General (Training)
Ministry of Skill Development & Entrepreneurship,
Government of India.

New Delhi - 110 001

PREFACE

The National Instructional Media Institute (NIMI) was established in 1986 at Chennai by then Directorate General of Employment and Training (D.G.E & T), Ministry of Labour and Employment, (now under Directorate General of Training, Ministry of Skill Development and Entrepreneurship) Government of India, with technical assistance from the Govt. of Federal Republic of Germany. The prime objective of this Institute is to develop and provide instructional materials for various trades as per the prescribed syllabi under the Craftsman and Apprenticeship Training Schemes.

The instructional materials are created keeping in mind, the main objective of Vocational Training under NCVT/NAC in India, which is to help an individual to master skills to do a job. The instructional materials are generated in the form of Instructional Media Packages (IMPs). An IMP consists of Theory book, Practical book, Test and Assignment book, Instructor Guide, Audio Visual Aid (Wall charts and Transparencies) and other support materials.

The trade practical book consists of series of exercises to be completed by the trainees in the workshop. These exercises are designed to ensure that all the skills in the prescribed syllabus are covered. The trade theory book provides related theoretical knowledge required to enable the trainee to do a job. The test and assignments will enable the instructor to give assignments for the evaluation of the performance of a trainee. The wall charts and transparencies are unique, as they not only help the instructor to effectively present a topic but also help him to assess the trainee's understanding. The instructor guide enables the instructor to plan his schedule of instruction, plan the raw material requirements, day to day lessons and demonstrations.

IMPs also deals with the complex skills required to be developed for effective team work. Necessary care has also been taken to include important skill areas of allied trades as prescribed in the syllabus.

The availability of a complete Instructional Media Package in an institute helps both the trainer and management to impart effective training.

The IMPs are the outcome of collective efforts of the staff members of NIMI and the members of the Media Development Committees specially drawn from Public and Private sector industries, various training institutes under the Directorate General of Training (DGT), Government and Private ITIs.

NIMI would like to take this opportunity to convey sincere thanks to the Directors of Employment & Training of various State Governments, Training Departments of Industries both in the Public and Private sectors, Officers of DGT and DGT field institutes, proof readers, individual media developers and coordinators, but for whose active support NIMI would not have been able to bring out this materials.

Chennai - 600 032

EXECUTIVE DIRECTOR

ACKNOWLEDGEMENT

National Instructional Media Institute (NIMI) sincerely acknowledges with thanks for the co-operation and contribution extended by the following Media Developers and their sponsoring organisation to bring out this IMP (**Trade Theory**) for the trade of **Drone Pilot (Junior) - NSQF Level - 3 (Revised 2022)** under the **Aerospace & Aviation** Sector for ITIs.

MEDIA DEVELOPMENT COMMITTEE MEMBERS

Shri. Kamil Naqvi - CEO, Hayedrone Flying Academy Pvt Ltd.
Amroha, Uttar Pradesh.

NIMI - COORDINATORS

Shri. Nirmalya Nath - Deputy Director,
NIMI, Chennai - 32.

Shri. S. Gopalakrishnan - Assistant Manager
NIMI, Chennai - 32.

NIMI records its appreciation of the Data Entry, CAD, DTP Operators for their excellent and devoted services in the process of development of this Instructional Material.

NIMI also acknowledges with thanks, the invaluable efforts rendered by all other staff who have contributed for the development of this Instructional Material.

NIMI is grateful to all others who have directly or indirectly helped in developing this IMP.

INTRODUCTION

TRADE PRACTICAL

The trade practical manual is intended to be used in practical workshop. It consists of a series of practical exercises to be completed by the trainees during the course. These exercises are designed to ensure that all the skills in compliance with NSQF Level - 3 (Revised 2022) syllabus are covered.

The manual is divided into Ten modules.

- Module 1 Safety regulations and guidelines
- Module 2 Identify & select different types of RPA
- Module 3 Identify & select various parts of RPA
- Module 4 Identify and compare the weather effects and analyze the performance of RPA
- Module 5 Perform installation, maintain and configuration of ground control station software
- Module 6 Perform pre flight inspection and assembling of basic RPA
- Module 7 Carryout basic training to fly RPA in flight simulator
- Module 8 Plan and organize training to fly RPA in controlled environments
- Module 9 Perform and obtain training to fly RPA in uncontrolled airspace including VLOS and BVLOS flight
- Module 10 Apply emergency protocols to control and manage RPA flight

The skill training in the shop floor is planned through a series of practical exercises centered around some practical project. However, there are few instances where the individual exercise does not form a part of project.

While developing the practical manual, a sincere effort was made to prepare each exercise which will be easy to understand and carry out even by below average trainee. However the development team accept that there is a scope for further improvement. NIMI looks forward to the suggestions from the experienced training faculty for improving the manual.

TRADE THEORY

The manual of trade theory consists of theoretical information for the Course of the **Drone Pilot (Junior)** Trade Theory NSQF Level - 3 (Revised 2022) in **Aerospace & Aviation**. The contents are sequenced according to the practical exercise contained in NSQF Level -3 (Revised 2022) syllabus on Trade Theory attempt has been made to relate the theoretical aspects with the skill covered in each exercise to the extent possible. This correlation is maintained to help the trainees to develop the perceptual capabilities for performing the skills.

The trade theory has to be taught and learnt along with the corresponding exercise contained in the manual on trade practical. The indications about the corresponding practical exercises are given in every sheet of this manual.

It will be preferable to teach/learn trade theory connected to each exercise at least one class before performing the related skills in the shop floor. The trade theory is to be treated as an integrated part of each exercise.

The material is not for the purpose of self-learning and should be considered as supplementary to class room instruction.

CONTENTS

Lesson No.	Title of the Lesson	Learning Outcome	Page No.
	Module 1 : Safety regulations and guidelines		
1.1.01	Familiar with industrial training institute		1
1.1.02	Importance of safety and general precautions observed in the industry/shop floor		3
1.1.03	First-aid		9
1.1.04	Guidelines for good shop floor maintenance	1	14
1.1.05	Occupational health and safety		17
1.1.06	Safety Sign		19
1.1.07-15	Importance of adopting a “safety attitude” when is flying a RPA		25
	Module 2 : Identify & select different types of RPA		
1.2.16-20	Different types of RPAS	2	34
	Module 3 : Identify & select various parts of RPA		
1.3.21-32	History of helicopter design	3	44
	Module 4 : Identify and compare the weather effects and analyze the performance of RPA		
1.4.33-35	Introduction to measurement systems and sensors	4	58
	Module 5 : Perform installation, maintain and configuration of ground control station software		
1.5.36-44	Introduction to telemetry	5	60
	Module 6 : Perform pre flight inspection and assembling of basic RPA		
1.6.45-50	Introduction to inspection procedures	6	63
	Module 7 : Carryout basic training to fly RPA in flight simulator		
1.7.51-58	Identify Basic operating features of an RPA flight simulator	7	67
	Module 8 : Plan and organize training to fly RPA in controlled environments		
1.8.59-68	Introduction to demonstrate RPA flying operation	8	69
	Module 9 : Perform and obtain training to fly RPA in uncontrolled airspace including VLOS and BVLOS flight		
1.9.69-76	What are VLOS, BVLOS, IFR, and VFR?	9	73

Lesson No.	Title of the Lesson	Learning Outcome	Page No.
1.10.77-81	Module 10 : Apply emergency protocols to control and manage RPA flight Apply emergency protocols to control and manage RPA flight	10	75

© NIMI
 NOT TO BE REPUBLISHED

LEARNING / ASSESSABLE OUTCOME

On completion of this book you shall be able to

S.No.	Learning Outcome	Ex.No
1	Interpret DGCA Safety Regulations & observe safety guidelines, ATC procedures & Radio Telephony, Weather and meteorology as a RPA Pilot in flying a RPA. AAS/N6301	1.1.01 - 1.1.15
2	Identify & select different types of RPA and illustrate Fundamentals of Flight (Aerodynamics) and Different Airframes in RPA flying. AAS/N9401	1.2.16 - 1.2.20
3	Identify & select various parts of RPA like assembling Electric motors, Batteries, Chargers, Connectors, Electronic Speed Controllers (ESC), Transmitters, Receivers, sensors and flight Controllers. AAS/N9402	1.3.21 - 1.3.32
4	Identify and compare the weather effects and analyze the performance of RPA. AAS/N6302	1.4.33 - 1.4.35
5	Perform installation, maintain and configuration of ground control station software. AAS/N6302	1.5.36 - 1.5.44
6	Perform preflight inspection and assembling of basic RPA parts like landing gears, propellers, antennas and any wire / electronics hanging outside. AAS/N6302	1.6.45 - 1.6.50
7	Carryout basic training to fly RPA in flight simulator. AAS/N9403	1.7.51 - 1.7.58
8	Plan and organize training to fly RPA in controlled environments. AAS/N6302	1.8.59 - 1.8.68
9	Perform and obtain training to fly RPA in uncontrolled airspace including VLOS and BVLOS flight. AAS/N6302	1.9.69 - 1.9.76
10	Apply emergency protocols to control and manage RPA flight. AAS/N9404	1.10.77 - 1.10.81

SYLLABUS

Duration	Reference Learning Outcome	Professional Skills (Trade Practical) with Indicative hours	Professional Knowledge (Trade Theory)
Professional Skill 65 Hrs; Professional Knowledge 20 Hrs	Interpret DGCA Safety Regulations & observe safety guidelines, ATC procedures & Radio Telephony, Weather and meteorology as a RPA Pilot in flying a RPA. AAS/N6301	<ol style="list-style-type: none"> 1. Visit to various sections of the institute and identify location of various installations. (02 hrs.) 2. Identify safety signs for danger, warning, caution & personal safety message. (03 hrs.) 3. Practice Use of Personal Protective Equipment (PPE). (02 hrs.) 4. Practice elementary first aid. (03 hrs.) 5. Practice Preventive measures for electrical accidents & steps to be taken in such accidents. (04hrs.) 6. Practice Use of Fire extinguishers. (04 hrs.) 7. Practice workshop safety norms. (05hrs.) 8. Identify safety rules while flying a RPA.(03hrs.) 9. Practice DGCA safety regulations, Do's and Don'ts. (03hrs.) 10. Recognize issues RPA pilots encounter including airspace, traffic patterns etc. (03hrs.) 11. Practice Radio telephony using Standard radio terminology and RT Phraseology. (07hrs.) 12. Communicate with virtual ATC including Position, Altitude Reporting etc. (07hrs.) 13. Identify specific Flight Planning Procedures for specific RPA flights. (06hrs.) 14. Recognize importance of Weather and meteorology in RPA flight. (06hrs.) 15. Take METAR from mini weather station and MET office/ ATC before flying. (07hrs.) 	<p>Familiarization with the working of Industrial Training Institute system. Importance of safety and precautions to be taken in the industry/ shop floor.</p> <p>Introduction to PPEs. Introduction to First Aid. Importance of housekeeping & good shop floor practices.</p> <p>Occupational Safety & Health: Health, Safety and Environment guidelines, legislations & regulations as applicable.</p> <p>Importance of adopting a “safety attitude” when is flying a RPA. Workshop safety norms and outdoor flying safety regulations.</p> <p>Regulations of DGCA, Civil Aviation Requirements: Classification, Basic Air Regulations, Salient points, Do's and Don'ts.</p> <p>Issues aircraft pilots encounter including airspace, traffic patterns, and safe attitudes.</p> <p>Understanding ATC operations Airspace Structure and Airspace Restrictions with knowledge of No RPA Zones Communicating with ATC including Position and Altitude Reporting Flight Planning Procedures Collision Avoidance Radio Telephony (RT) techniques Standard radio terminology and RT Phraseology Practice Session in Radio Communication.</p> <p>Weather and meteorology: The standard atmosphere, Measuring air pressure, Heat and temperature, Wind, Moisture, cloud formation</p> <p>Met Terminal Aviation Routine Weather Report (METAR). (20 Hrs.)</p>
Professional Skill 38 Hrs; Professional Knowledge 12 Hrs	Identify & select different types of RPA and illustrate Fundamentals of Flight (Aerodynamics) and Different Airframes in RPA flying. AAS/N9401	<ol style="list-style-type: none"> 16. Identify Different types of RPAS. (06 hrs.) 17. Select basic components and RPAS. (07 hrs.) 18. Fundamentals of flight aerodynamics (07 hrs.) 19. Recognize basic principles of flying like Bernoulli's Principle etc. (08 hrs.) 20. Apply principles of flight to RPAS. (10hrs.) 	<p>Different types of RPAS, Nomenclatures, and History of aerial RPAS, reputation, airframe, configurations, basic components, and current/future uses of RPAS.</p> <p>Introduction to aerodynamics, history of Flight, Newton's Laws of Motion, Bernoulli's Principle, four forces of Flight, three axes of Flight how they apply to RPA Flight. (12 Hrs)</p>

Professional Skill 78 Hrs; Professional Knowledge 20 Hrs	Identify & select various parts of RPA like assembling Electric motors, Batteries, Chargers, Connectors, Electronic Speed Controllers (ESC), Transmitters, Receivers, sensors and flight Controllers. AAS/N9402	21. Identify each component in RPAS. (03hrs.) 22. Perform assembling & disassembling of RPAS. (07hrs.) 23. Recognize multi rotor design, various configurations, airframe sizes and construction materials. (07hrs.) 24. Identify different propeller designs and choose appropriate propeller. (06hrs.) 25. Electricity fundamentals (Wattage, voltage, Amperage and their relationship) and soldering techniques. (10hrs.) 26. Calculate motor ratings for load capabilities for a RPA build. (07hrs.) 27. Identify parallel vs. serial arrangements of batteries. (07hrs.) 28. Practice charging, cell balancing and explore various connectors. (10hrs.) 29. Identify different role of FCs and ESCs. And its calibration (10hrs.) 30. Recognize different sensors & their applications in RPAS. (04hrs.) 31. Identify GPS applications in RPA flying. (04hrs.) 32. Identify different radio control systems, controllers, transmitters and receivers, Frequency bands and. (04hrs.)	History of helicopter design, early multi rotor design, various Configurations, airframe sizes and construction materials. History of propeller design, fixed-pitch and constant speed blades, airfoil design, size, pitch, and blade-count including balancing tips and construction materials. History of batteries, various makeup's, reactions and chemistry, parallel vs. serial arrangements, rechargeable batteries, Li-Po battery characteristics, charging, cell balancing and various connectors. AC/DC motor differences, amperage and voltage ratings, history of electric motors, brushed vs. brushless motors, Kv ratings, and calculations of motor capabilities for a RPA build. Introduction to the history radio control systems, controllers, transmitters and receivers, Frequency bands and programming transmitters. Introduction to role of ESCs, how they work, PWM, PPM, ESC calibration, Simon KVs. BLHeli firmware options and BEC, OPTO, and UBEC. Introduction to role offlight controllers, how they work, Introduction to sensors, Sense-and-avoid technology, GPS, open source vs. closed source programming, and comparison of current FCs on the market. (20 Hrs.)
Professional Skill 15Hrs; Professional Knowledge 06 Hrs	Identify and compare the weather effects and analyze the performance of RPA. AAS/N6302	33. Identify the factors that influence the performance of the RPAS. (04 hrs.) 34. Identify and learn measurement of atmosphere pressure, effect of obstructions on wind speed and direction. (05hrs.) 35. Identify and learn measurement of temperature and humidity, Rain and solar radiation. (06 hrs.)	Introduction to measurement systems and sensors. To develop a basic understanding of the principles involved in measurements. To introduce the state-of-the-art sensors for various engineering applications. Different types of sensors operate in very different ways. Data on the weather qualities of each specific sensor must be obtained prior to implementation. Sensors and platforms; To enable the students to interface the sensors with RPA platforms. (06 hrs.)
Professional Skill 38 Hrs; Professional Knowledge 12 Hrs	Perform installation, maintain and configuration of ground control station software. AAS/N6302	36. Knowledge of GCS telemetry and Track RPA using telemetry. (02hrs.) 37. Learn GCS features and possible flight plans using GCS. (03hrs.) 38. Identify Flight mode operation, GUI parameters, Maps and user control operation. (03hrs.)	Introduction to telemetry, data tracking, mission planning, and 3D mapping and modeling. First-person-view (FPV) flying, safety and drone racing options. Introduction to ground control station software and its features. What is RPA Data? What Types of data are there?

		<p>39. Autonomous Waypoint Navigation and Dynamic flight plan adjustment. (02 hrs.)</p> <p>40. Perform 3D mapping and modeling. (03 hrs.)</p> <p>41. Perform Geographic Map along with UAV location, UAV trajectory, camera view polygon, waypoints and flight plan. (04 hrs.)</p> <p>42. Collect and explore Flight data, Sensor data, Flight planning data, Airspace and weather data. (07hrs.)</p> <p>43. Platform Analytics: including performance figures on orders, missions, inspections, flights, pilots, and data. (07hrs.)</p> <p>44. Data Mapping and Navigation: with a graphical user interface to navigate across 2D/3D models, visualize on maps, and click through images. (07hrs.)</p>	<p>How to analyze and report on RPADData, RPA Imaging Data? Data & Analytics: How to Report on Missions. The data collected from these RPA images can then be measured, analyzed, tracked, and compared over time. (12 hrs.)</p>
<p>Professional Skill 38 Hrs; Professional Knowledge 12 Hrs</p>	<p>Perform pre flight inspection and assembling of basic RPA parts like landing gears, propellers, antennas and any wire / electronics hanging outside. AAS/N6301</p>	<p>45. Learn all three inspection procedures. (02hrs.)</p> <p>46. Prepare the checklist immediately before piloting a RPA to ensure best practice for mission success. (03hrs.)</p> <p>47. Perform assembly of landing gears, propellers, antennas and electronics. (07hrs.)</p> <p>48. Remotely-piloted aircraft system (RPAS) controls, know your remote control, safety precautions, pre-flight checks, arming and disarming. (10hrs.)</p> <p>49. Method of RPA inspection charging the battery Cleaning the RPA Storage Maintenance resources and standards. (06hrs.)</p> <p>50. Perform assembly of Gimble, camera and base station hardware and software setup. (10hrs.)</p>	<p>Introduction to inspection procedures.</p> <p>History of propeller design, fixed-pitch and constant speed blades, airfoil design, size, pitch, and blade-count including balancing tips and construction materials.</p> <p>Knowledge about remote control, safety precautions, pre-flight checks, arming and disarming.</p> <p>Procedures of Charging the battery, importance of Cleaning the RPA Storage Maintenance resources and standards. (12 hrs)</p>
<p>Professional Skill 38 Hrs; Professional Knowledge 12 Hrs</p>	<p>Carryout basic training to fly RPA in flight simulator. AAS/N9403</p>	<p>51. Identify Basic operating features of a RPA flight simulator. (02hrs.)</p> <p>52. Select different aircrafts/RPAS and aerodromes. (03hrs.)</p> <p>53. Carry out Demo flight in RPA Flight Simulator with Pre-flight checks, start-up, Take-off RPA and carry out flight stage. (6 hrs.)</p> <p>54. Do Approach and safe landing, perform post flight checks and identify emergency, Loss of link, Loss of power, Control surface</p>	<p>Basic operating features of a RPA flight simulator, How to select different aircrafts/RPAS and aerodromes, knowledge of Demo flight.</p> <p>Introduction to demonstrate solo flight training and Live RPA flying, Flight Operation, Flying a RPA in simulator training.</p> <p>Introduction to photogrammetry for stitching and analysis of RPA pictures. (12 hrs)</p>

		<p>failures etc. (03 hrs.)</p> <p>55. Perform Practical flying with and without instructor in RPA simulator. (07 hrs)</p> <p>56. Fly RPARPA in Simulator. RPA. (07 hrs)</p> <p>57. Carry out entire flying operations from pre-flight checks to after flight checks while flying RPA with instructor and solo flying RPA. (07 Hrs)</p> <p>58. Demonstrate Handling in flight emergencies, fail safe mechanisms. (03 Hrs)</p>	
<p>Professional Skill 38 Hrs; Professional Knowledge 12 Hrs</p>	<p>Plan and organize training to fly RPA in controlled environments. AAS/N6302</p>	<p>59. Carry out First-person-view (FPV) flying. (02hrs.)</p> <p>60. RPA Understand the requirement of flying RPA in a controlled environment. (03hrs.)</p> <p>61. RPAS controls, safety precautions, pre-flight checks, takeoff, learn basic flight modes such as manual, stabilize, alt hold and land. (03hrs.)</p> <p>62. Practice flying the RPAS in left/right and forward/backward motion, square pattern, circle. (03hrs.)</p> <p>63. Practice flight mode such as takeoff, loiter, alt hold. (03hrs.)</p> <p>64. Learn to land in GPS failsafe, radio failsafe and battery failsafe. (03hrs.)</p> <p>65. Learn to upgrade the autopilot / system firmware and test the machine in a controlled environment. (12hrs.)</p> <p>66. Explore camera options, resolution and perform operation to full camera controls Pan/Tilt & Zoom In/Out. (03hrs.)</p> <p>67. Plan & estimate payload considerations, camera options, resolution etc. & other payload possibilities. (03hrs.)</p> <p>68. Identify different payloads including cameras like Lidar, Thermal, RGB, Hyper spectral etc. (03hrs.)</p>	<p>Introduction to demonstrate RPA flying operation, Flying a RPA in controlled environment with different modes of operation.</p> <p>Overview of the main quad copter parts, choosing a place to learn how to fly an RPA, how to get your RPA off the ground, flying your quad copter left/right and forwards/backwards, Beginner and Advanced RPA flying techniques.</p> <p>Introduction to Payload considerations, camera options, resolution, still photography, video photography, GPS modes, vibration and Jello effect, exposure settings, camera lenses, video Frame rate, image files, camera payloads, and other payload possibilities.</p>
<p>Professional Skill 17 Hrs; Professional Knowledge 07 Hrs</p>	<p>Perform and obtain training to fly RPA in uncontrolled airspace including VLOS and BVLOS flight. AAS/N6302</p>	<p>69. Apply knowledge of VLOS (visual line of sight) and BVLOS (Beyond Visual Line Of Sight) and identify safety practices for BVLOS and VLOS. (02hrs.)</p>	<p>What are VLOS, BVLOS, IFR, and VFR? Why do they affect RPA operations? What rules and restrictions apply to flights performed in 'visual line of sight' (VLOS) and 'beyond visual line of sight' (BVLOS)?</p>

		<p>70. Perform Secure Communication link between UAV and GCS. (01hr.)</p> <p>71. Identify & select other payload possibilities. (01hr.)</p> <p>72. Identify different payloads including cameras like Lidar, Thermal, RGB, Hyper spectral etc. (03hrs.)</p> <p>73. Perform autonomous waypoint navigation (pre-defined as well as dynamically adjustable waypoints during flight). (03hrs.)</p> <p>74. Remotely Piloted mode for video-based navigation (RPV Mode). (01hrs.)</p> <p>75. Learn Geographic Map along with UAV location, UAV trajectory, camera view polygon, waypoints and flight plan. (03hrs.)</p> <p>76. Fly RPA for application specific including Surveillance, Agriculture and Inspection. (02hrs.)</p>	<p>Introduction of different payload like cameras, thermal cameras, Lidar sensor, RGB and Hyper spectral cameras. Payload connection and its operation procedure to for RPA Flight in a uncontrolled environment.</p> <p>How to choose a RPA based on the application different sectors like agriculture, inspection and etc. (07 hrs)</p>
<p>Professional Skill 55 Hrs; Professional Knowledge 07 Hrs</p>	<p>Apply emergency protocols to control and manage RPA flight. AAS/N9404</p>	<p>77. Identify emergency and handle it accordingly. (03Hrs.)</p> <p>78. Learn instrument flying rules using manual/ semi-autonomous flight modes. (05hrs.)</p> <p>79. Identify emergencies like Aircraft structural failure, loss of power – battery, motor, Loss of GPS and loss of lights at night. (03Hrs.)</p> <p>80. Maintain Visual Line of Sight (VLOS) with the aircraft for as long as possible. (03Hrs.)</p> <p>81. Learn where to fly and how to fly legally and how you fly it in uncontrolled airspace. (05Hrs.)</p>	<p>Introduction to the safety risks Guidelines to fly RPA, UAV Regulations in India,</p> <p>Personal Safety, UAV Operations & Safety, Regulatory and regulations, Emergency identification and handling, In flight emergencies Loss of link, Fly-away(Straying), Loss of power, Control surface failures.</p>

Familiar with industrial training institute

Objectives: At the end of this lesson you shall be able to

- explain about DGT affiliated institutions under MSDE
 - familiarise with working of ITI using organisational chart of ITI
 - state the function of store procedures in training institutes.
-

Introduction**Directorate General of Training (DGT)**

Directorate General of Training (DGT) in Ministry of Skill Development & Entrepreneurship is an apex organization for development and coordination of the vocational training including Women's Vocational Training of the employable youth in the country and to provide skilled manpower to the economy.

Two verticals of Directorate General of Employment & Training (DGE&T) working under Deputy Director General (Training) & Deputy Director General (Apprenticeship Training) along with their support systems were transferred to Ministry of Skill Development & Entrepreneurship (MSDE).

DGT affiliated institutions offers a wide range of training courses catering to the needs of different segments in the Labour market. Courses are available for school leavers, ITI pass outs, ITI instructors, industrial workers, technicians, junior and middle level executives, supervisors/foremen, women, physically disabled persons and SC/STs.

It also conducts training oriented research and develops instructional media packages for the use of trainees and instructors etc.

DGT acts a secretariat and implementing arm of National Council for Vocational Training (NCVT).

Training Institutes under DGT

- 13350 Industrial Training institutes (ITIs)
- 31 Central Institutes
- 10 Advanced Training Institutes (ATIs)
- 2 ATI-EPIs (Advanced Training Institutes - Electronic Process Instrumentation)
- 2 Foremen Training Institutes (FTIs)
- 1 Central Training Institutes (CTI)
- 1 National Vocational Training Institute (NVTI) for Women
- 15 Regional Vocational Training Institutes (RVTIs) for Women
- 12 Private Institute for Training of Trainers (IToTs)
- 2 State Government IToTs
- Central Staff Training and Research Institute (CSTAR)
- National Instructional Media Institute (NIMI)

Familiar with the working of Industrial Training Institute system including stores procedures

Objectives: At the end of this lesson you shall be able to

- to familiarise with working of ITI
- identify the staff structure of the institute
- identify the available trades in the institute and their function
- brief about the stores procedure.

The industrial training institute throughout India follow the same syllabus pattern given by the National council for Vocational Training (NCVT). In India there are about 13,350 Government ITIs and Private ITI 's Based on the Govt. of India, Ministry of Skill Development and Entrepreneurship (MSDE) Annual report of 2016-2017. The Government Industrial Training Institute in each state work under the Directorate of Employment and Training which is a department under the Labour Ministry in most of the states.

The head of the industrial training institute is the Principal, under whom there is one vice-principal, Group Instructor(s) Training officers and a number of Vocational Instructor(s) Assitant Training Officer(s) and Junior Training Officer and so on as shown in the Organisation Chart of ITI. (Fig 1)

In every industrial training institute there is a store and the in charge of the store is storekeeper for inward and outward movement of tools, equipment and consumable. The instructor will indent the training requirement on receiving from stores, the instructor will issue the training requirement to the trainees according to the graded exercises as per syllabus.

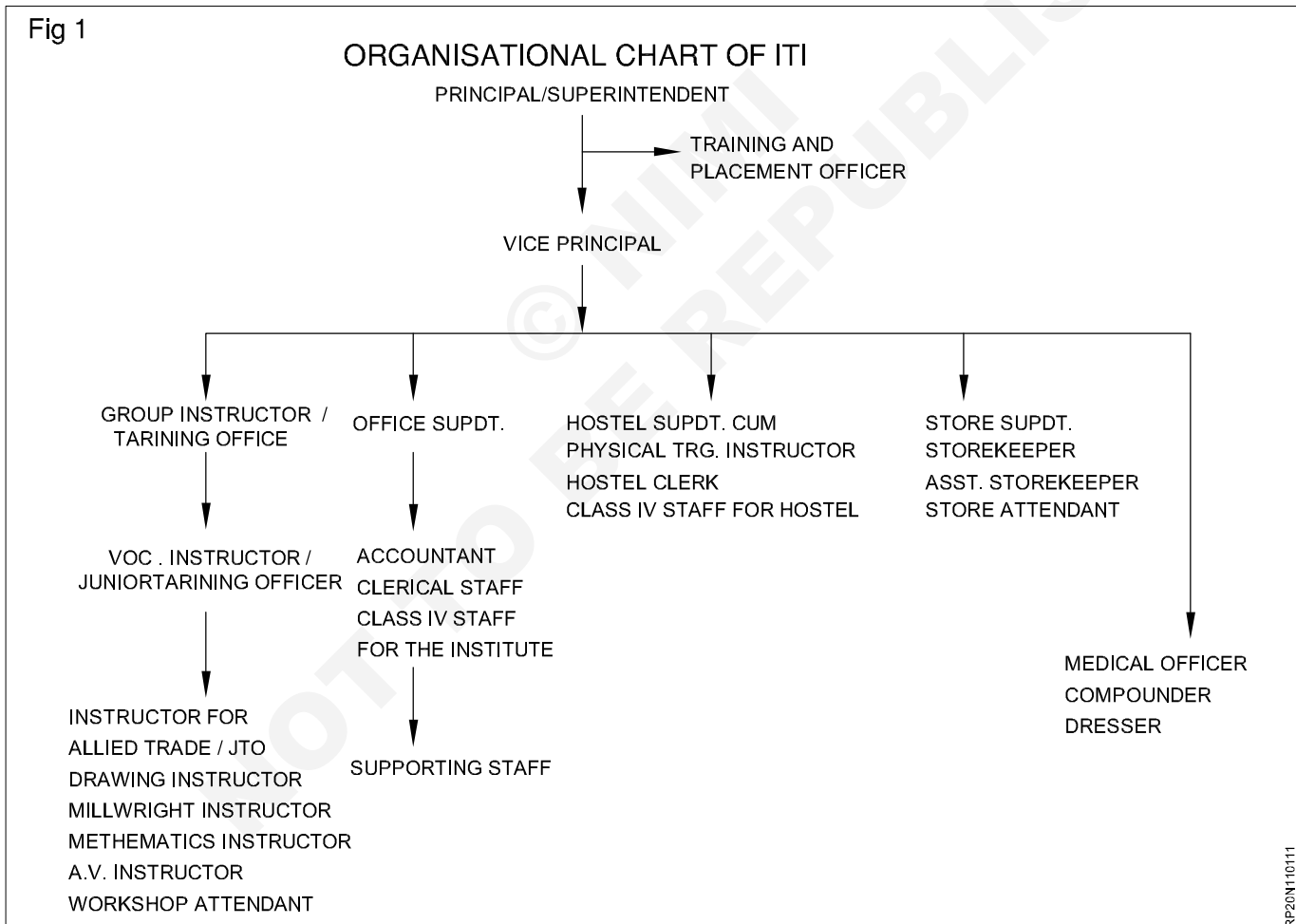

Importance of safety and general precautions observed in the industry/shop floor

Objectives: At the end of this lesson you shall be able to

- state the importance of safety
- list out the safety precautions to be observed in a industry/shop floor
- list out the personal safety precautions to be observed in machine shop
- list out the safety precautions to be observed while working on the machines.

Generally accidents do not happen; they are caused. Most accidents are avoidable. A good craftsman, having a knowledge of various safety precautions, can avoid accidents to himself and to his fellow workers and protect the equipment from any damage. To achieve this, it is essential that every person should follow safety procedure. (Fig 1)

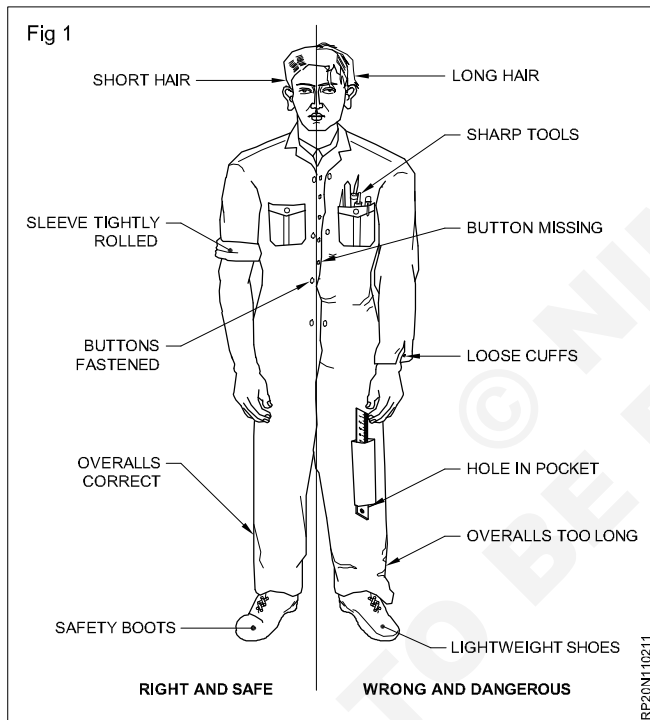

Safety in a workshop can be broadly classified into 3 categories.

- General safety
- Personal safety
- Machine safety

General safety

- Keep the floor and gangways clean and clear.
- Move with care in the workshop, do not run.
- Don't leave the machine which is in motion.
- Don't touch or handle any equipment/ machine unless authorised to do so.
- Don't walk under suspended loads.
- Don't cut practical jokes while on work.

- Use the correct tools for the job.
- Keep the tools at their proper place.
- Wipe out split oil immediately.
- Replace worn out or damaged tools immediately.
- Never direct compressed air at yourself or at your co-worker.
- Ensure adequate light in the workshop.
- Clean the machine only when it is not in motion.
- Sweep away the metal cuttings.
- Know everything about the machine before you start it.

Personal safety

- Wear a one piece overall or boiler suit.
- Keep the overall buttons fastened.
- Don't use ties and scarves.
- Roll up the sleeves tightly above the elbow.
- Wear safety shoes or boots
- Cut the hair short.
- Don't wear a ring, watch or chain.
- Never lean on the machine.
- Don't clean hands in the coolant fluid.
- Don't remove guards when the machine is in motion.
- Don't use cracked or chipped tools.
- Don't start the machine until
 - the workpiece is securely mounted
 - the feed machinery is in the neutral
 - the work area is clear.
- Don't adjust clamps or holding devices while the machine is in motion.
- Never touch the electrical equipment with wet hands.
- Don't use any faulty electrical equipment.
- Ensure that electrical connections are made by an authorised electrician only.
- Concentrate on your work. Have a calm attitude.

Do things in a methodical way.

Don't engage yourself in conversation with others while concentrating on your job.

Don't distract the attention of others.

Don't try to stop a running machine with hands.

Machine safety

Switch off the machine immediately if something goes wrong.

Keep the machine clean.

Replace any worn out or damaged accessories, holding devices, nuts, bolts etc as soon as possible.

Do not attempt operating the machine until you know how to operate it properly.

Do not adjust tool or the workpiece unless the power is off.

Stop the machine before changing the speed.

Disengage the automatic feeds before switching off.

Check the oil level before starting the machine.

Never start a machine unless all the safety guards are in position.

Take measurements only after stopping the machine.

Use wooden planks over the bed while loading and unloading heavy jobs.

Safety is a concept, understand it. Safety is a habit, cultivate it.

Approach on soft skills

Objectives : At the end of this lesson you shall be to

- **state the concept of soft skill**
- **list the important common soft skills**
- **brief the employability aspect of training**
- **brief the further learning scope.**

Concept

Soft skills - refer to the cluster of personality traits, social graces, facility with language, personal habits, friendliness, and optimism that mark people to varying degrees. The same can also be defined as-ability to interact communicate positively & productively with others. Sometimes called "character skills".

More and more business are considering soft skills as important job criteria. Soft skills are used in personal and professional life. Hard skills/technical skills do not matter without soft skills.

Common Soft Skills

- Strong work ethic
- Positive attitude
- Good communication skills
- Interpersonal skills
- Time management abilities
- Problem-solving skills
- Team work
- Initiative, Motivation
- Self-confidence
- Loyalty
- Ability to accept and learn from criticism
- Flexibility, Adaptability
- Working well under pressure

Job area completion of training: This highlights the employability aspect on completion of training. The trainee should be aware of various prospects available in present market scenario along with scope for self-employment. For example a trainee with NTC engineering trade may opt for:

Various job available in different industries in India and Abroad.

After successful completion of ITI training in any one of the engineering trade one can see appointment in engineering workshop/Factories (Public Sector, Private Sector and Government Industries) in India and Abroad as technician/Skilled worker.

Self employment

One can start his own factory/ancillary unit or design products manufacture and became an entrepreneur.

Further learning scope

- Apprentice training in designated trade.
- Craft Instructor certificate course.
- Diploma in relevant Engineering.

Personal Protective Equipment (PPE)

Objectives: At the end of this lesson you shall be able to

- state what is personal protective equipment and its purpose
- name the two categories of personal protective equipment
- list the most common type of personal protective equipment
- list the conditions for selection of personal protective equipment.

Personal Protective Equipment (PPE)

Devices, equipments, or clothing used or worn by the employees, as a last resort, to protect against hazards in the workplace. The primary approach in any safety effort is that the hazard to the workmen should be eliminated or the workmen through the use of personal protective controlled by engineering methods rather than protecting the workmen through the use of personal protective equipment (PPE). Engineering methods could include design change, substitution ventilation, mechanical handling, automation, etc. in situations where it is not possible to introduce any effective engineering methods for controlling hazards, the workman shall use appropriate types of PPE.

As changing times have modernized the workplace, government and advocacy groups have brought more safety standards to all sorts of work environments. The Factories Act, 1948 and several other labour legislations 1996 have provisions for effective use of appropriate types of PPE. Use of PPE is very important.

Ways to ensure workplace safety and use personal protective equipment (PPE) effectively.

- Workers to get up-to date safety information from the regulatory agencies that oversees workplace safety in their specific area.
- To use all available text resources that may be in work area and for applicable safety information on how to use PPE best.
- When it comes to the most common types of personal protective equipment, like goggles, gloves or bodysuits, these items are much less effective if they are not worn at all times, or whenever a specific danger exists in a work process. Using PPE consistently will help to avoid some common kinds of industrial accidents.
- Personal protective gear is not always enough to protect workers against workplace dangers, Knowing more about the overall context of your activity can help to fully protect from anything that might threaten health and safety on the job.

- Inspection of gear throughly to make sure that it has the standard of quality and adequately protect the user should be continuously carried out.

Categories of PPE-Small's'

Depending upon the nature of hazard, the PPE is broadly divided into the following two categories.

Non-respiratory : Those used for protection against injury from outside the body, i.e. for protecting the head,eye, face, hand, arm, foot, leg and other body parts

Respiratory: Those used for protection from harm due to inhalation of contaminated air.

They are to meet the applicable BIS (Bureau of Indian Standards) standards for different types of PPE.

The guidelines on 'Personal Protective Equipment' is issued to facilitate the plant management in maintaining an effective programme with respect to protection of persons against hazards, which cannot be eliminated or controlled by engineering methods listed in table 1.

Table 1

No	Title
PPE1	Helmet
PPE2	Safety footwear
PPE3	Respiratory protective equipment
PPE4	Arms and hands protection
PPE5	Eyes and face protection
PPE6	Protective clothing and coverall
PPE7	Ears protection
PPE8	Safety belt harness

Personal protective equipments and their uses and hazards are listed in Table 2

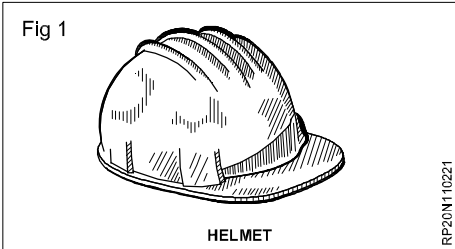
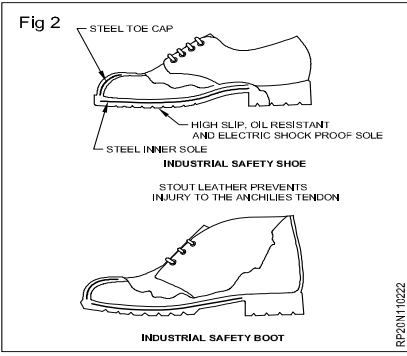
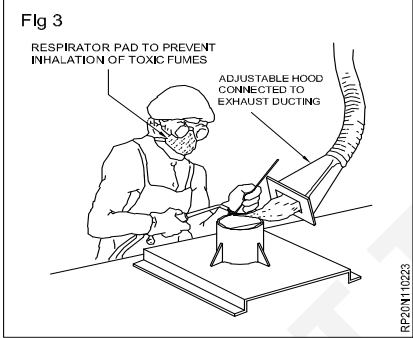
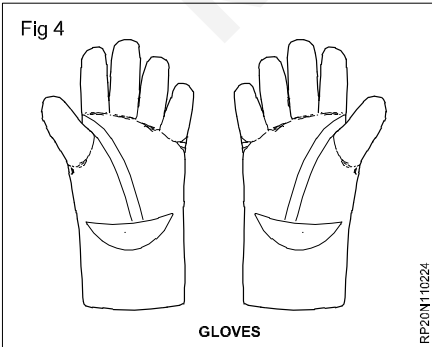
Types of protection	Hazards	PPE to be used
<p>Head protection (Fig 1)</p> 	<ol style="list-style-type: none"> 1. Falling objects 2. Striking against objects 3. Spatter 	<p>Helmets</p>
<p>Foot protection (Fig 2)</p> 	<ol style="list-style-type: none"> 1. Hot spatter 2. Falling objects 3. Working wet area 	<p>Leather leg guards Safety shoes Gum boots</p>
<p>Nose (Fig 3)</p> 	<ol style="list-style-type: none"> 1. Dust particles 2. Fumes/gases/ vapours 	<p>Nose mask</p>
<p>Hand Protection (Fig 4)</p> 	<ol style="list-style-type: none"> 1. Heat burn due to direct contact 2. Blows spark moderate heat 3. Electric shock 	<p>Hand gloves</p>

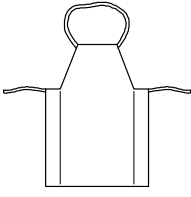
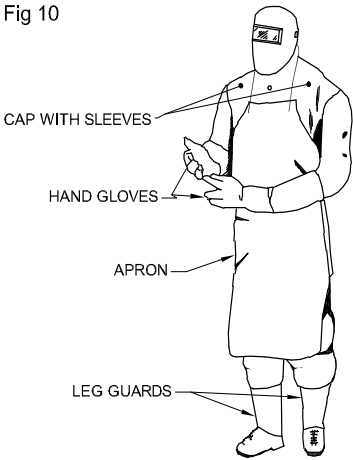
Types of protection	Hazards	PPE to be used
<p>Body protection (Fig 8, & Fig 9)</p> <div data-bbox="116 293 550 533"> <p>Fig 9</p>  <p>APRON</p> <p>RP20NF10229</p> </div> <div data-bbox="116 613 550 1128"> <p>Fig 10</p>  <p>CAP WITH SLEEVES</p> <p>HAND GLOVES</p> <p>APRON</p> <p>LEG GUARDS</p> <p>LEG GUARDS</p> <p>RP20NF1022A</p> </div>	<p>1. Hot particles</p>	<p>Leather aprons</p>

Quality of PPE's

PPE must meet the following criteria with regard to its quality-provide absolute full protection against possible hazard and PPE's be so designed and manufactured out of materials that it can withstand the hazards against which it is intended to be used.

Selection of PPE's requires certain conditions

- Nature and severity of the hazard
- Type of contaminant, its concentration and location of contaminated area with respect to the source of respirable air
- Expected activity of workman and duration of work, comfort of workman when using PPE
- Operating characteristics and limitation of PPE
- Easy of maintenance and cleaning
- Conformity to Indian / International standards and availability of test certificate.

Proper use of PPEs

Having selected the proper type of PPE, it is essential that the workman wears it. Often the workman avoids using PPE. The following factors influence the solution to this problem.

- The extent to which the workman understands the necessity of using PPE
- The ease and comfort with which PPE can be worn with least interference in normal work procedures
- The available economic, social and disciplinary sanctions which can be used to influence the attitude of the workman
- The best solution to this problem is to make wearing of PPE' mandatory for every employee.
- In other places, education and supervision need to be intensified. When a group of workmen are issued PPE for the first time.

Drone Pilot (Junior) - Safety regulations and guidelines

First-aid

Objectives: At the end of this lesson you shall be able to

- state what is first aid
- list the key aims of first aid
- explain the ABC of the first aid
- brief how to give first-aid for a victim who need first aid.

First aid is defined as the immediate care and support given to an acutely injured or ill person, primarily to save life, prevent further deterioration or injury, plan to shift the victims to safer places, provide best possible comfort and finally help them to reach the medical centre/ hospital through all available means. It is an immediate life-saving procedure using all resources available within reach.

Imparting knowledge and skill through institutional teaching at younger age group in schools, colleges, entry point at industry level is now given much importance. Inculcating such habits at early age, helps to build good healthcare habits among people.

First aid procedure often consists of simple and basic life saving techniques that an individual performs with proper training and knowledge.

The key aims of first aid can be summarized in three key points:

- **Preserve life:** If the patient was breathing, a first aider would normally place them in the recovery position, with the patient leant over on their side, which also has the effect of clearing the tongue from the pharynx. It also avoids a common cause of death in unconscious patients, which is choking on regurgitated stomach contents. The airway can also become blocked through a foreign object becoming lodged in the pharynx or larynx, commonly called choking. The first aider will be taught to deal with this through a combination of 'back slaps' and 'abdominal thrusts'. Once the airway has been opened, the first aider would assess to see if the patient is breathing.
- **Prevent further harm:** Also sometimes called prevent the condition from worsening, or danger of further injury, this covers both external factors, such as moving a patient away from any cause of harm, and applying first aid techniques to prevent worsening of the condition, such as applying pressure to stop a bleed becoming dangerous.
- **Promote recovery:** First aid also involves trying to start the recovery process from the illness or injury, and in some cases might involve completing a treatment, such as in the case of applying a plaster to a small wound.

Training

Basic principles, such as knowing to use an adhesive bandage or applying direct pressure on a bleed, are often acquired passively through life experiences. However, to

provide effective, life-saving first aid interventions requires instruction and practical training. This is especially true where it relates to potentially fatal illnesses and injuries, such as those that require cardiopulmonary resuscitation (CPR); these procedures may be invasive, and carry a risk of further injury to the patient and the provider. As with any training, it is more useful if it occurs before an actual emergency, and in many countries, emergency ambulance dispatchers may give basic first aid instructions over the phone while the ambulance is on the way. Training is generally provided by attending a course, typically leading to certification. Due to regular changes in procedures and protocols, based on updated clinical knowledge, and to maintain skill, attendance at regular refresher courses or re-certification is often necessary. First aid training is often available through community organization such as the Red cross and St. John ambulance.

ABC of first aid

ABC stands for airway, breathing and circulation.

- **Airway:** Attention must first be brought to the airway to ensure it is clear. Obstruction (choking) is a life-threatening emergency.
- **Breathing:** Breathing if stops, the victim may die soon. Hence means of providing support for breathing is an important next steps. There are several methods practiced in first aid.
- **Circulation:** Blood circulation is vital to keep person alive. The first aiders now trained to go straight to chest compressions through CPR methods.

When providing first aid one needs to follow some rule. There are certain basic norms in teaching and training students in the approach and administration of first aid to sick and injured.

Not to get panic

Panic is one emotion that can make the situation more worse. People often make mistake because they get panic. Panic clouds thinking and causes mistakes. First aider need calm and collective approach. If the first aider himself is in a state of fear and panic gross mistakes may result. It's far easier to help the suffering, when they know what they are doing, even if unprepared to encounter a situation. Emotional approach and response always lead to wrong doing and may cloud one to do wrong procedures. Hence be calm and focus on the given institution. Quick and confident approach can lessen the effect of injury.

Call medical emergencies

If the situation demands, quickly call for medical assistance. Prompt approach may save the life.

Surroundings play vital role

Different surroundings require different approach. Hence first aider should study the surrounding carefully. In other words, one need to make sure that they are safe and are not in any danger as it would be of no help that the first aider himself get injured.

Do no harm

Most often over enthusiastically practiced first aid viz. administering water when the victim is unconscious, wiping clotted blood (which acts as plug to reduce bleeding), correcting fractures, mishandling injured parts etc., would leads to more complication. Patients often die due to wrong FIRST AID methods, who may otherwise easily survive. Do not move the injured person unless the situation demands. It is best to make him lie wherever he is because if the patient has back, head or neck injury, moving him would causes more harm.

This does not mean do nothing. It means to make sure that to do something the care givers feel confident through training would make matters safe. If the first aider is not confident of correct handling it is better not to intervene of do it. Hence moving a trauma victim, especially an unconscious one, need very careful assessment. Removals of an embedded objects (Like a knife, nail) from the wound may precipitate more harm (e.g. increased bleeding). Always it is better to call for help.

Reassurance

Reassure the victim by speaking encouragingly with him.

Stop the bleeding

If the victim is bleeding, try to stop the bleeding by applying pressure over the injured part.

Golden hours

India have best of technology made available in hospitals to treat devastating medical problem viz. head injury, multiple trauma, heart attack, strokes etc, but patients often do poorly because they don't gain access to that technology in time. The risk of dying from these conditions, is greatest in the first 30 minutes, often instantly. This period is referred to as Golden period. By the time the patient reach hospitals, they would have passed that critical period. First aid care come handy to save lives. It helps to get to the nearest emergency room as quickly as possible through safe handling and transportation. The shorter that time, the more likely the best treatment applied.

Maintain the hygiene

Most importantly, first aider need to wash hands and dry before giving and first aid treatment to the patient or wear gloves in order to prevent infection.

Cleaning and dressing

Always clean the wound thoroughly before applying the bandage lightly wash the wound with clean water.

Not to use local medications on cuts or open wounds

They are more irritating to tissue than it is helpful. Simple dry cleaning or with water and some kind of bandage are best.

CPR (Cardio-Pulmonary Resuscitation) can be life-sustaining

CPR can be life sustaining. If one is trained in CPR and the person is suffering from choking or finds difficulty in breathing, immediately begin CPR. However, if one is not trained in CPR, do not attempt as you can cause further injury. But some people do it wrong. This is a difficult procedure to do in a crowded area. Also there are many studies to suggest that no survival advantage when bystanders deliver breaths to victims compared to when they only do chest compressions. Second, it is very difficult to carry right maneuver in wrong places. But CPR, if carefully done by highly skilled first aiders is a bridge that keeps vital organs oxygenated until medical team arrives.

Declaring death

It is not correct to declare the victim's death at the accident site. It has to be done by qualified medical doctors.

How to report an emergency?

Reporting an emergency is one of those things that seems simple enough, until actually when put to use in emergency situations. A sense of shock prevail at the accident sites. Large crowd gather around only with inquisitive nature, but not to extend helping hands to the victims. This is common in road side injuries. No passerby would like to get involved to assist the victims. Hence first aid management is often very difficult to attend to the injured persons. The first aiders need to adapt multitask strategy to control the crowd around, communicate to the rescue team, call ambulance etc., all to be done simultaneously. The mobile phones helps to a greater deal for such emergencies. Few guidelines are given below to approach the problems.

Assess the urgency of the situation. Before you report an emergency, make sure the situation is genuinely urgent. Call for emergency services if you believe that a situation is life-threatening or otherwise extremely disruptive.

- A crime, especially one that is currently in progress. If you're reporting a crime, give a physical description of the person committing the crime.
- A fire - If you're reporting a fire, describe how the fire stated and where exactly it is located. If someone has already been injured or is missing, report that as well.
- A life-threatening medical emergency, explain how the incident occurred and what symptoms the person currently displays.
- A car crash - Location, serious nature of injuries, vehicle's details and registration, number of people involved etc.

Call emergency service

The emergency number varies - 100 for Police & Fire. 108 for Ambulance.

Report your location

The first thing the emergency dispatcher will ask is where you are located, so the emergency services can get there as quickly as possible. Give the exact street address, if you're not sure of the exact address, give approximate information.

Give the dispatcher your phone number

This information is also imperative for the dispatcher to have, so that he or she is able to call back if necessary.

Describe the nature of the emergency

Speak in a calm, clear voice and tell the dispatcher why you are calling. Give the most important details first, then answer the dispatcher's follow-up question as best as you can.

Do not hang up the phone until you are instructed to do so. Then follow the instructions you were given.

Basic first aid

Basic first aid refers to the initial process of assessing and addressing the needs of someone who has been injured or is in physiological distress due to choking, a heart attack, allergic reactions, drugs or other medical emergencies. Basic first aid allows one to quickly determine a person's physical condition and the correct course of treatment.

Important guideline for first aiders

Evaluate the situation

Are there things that might put the first aider at risk. When faced with accidents like fire, toxic smoke, gasses, an unstable building, live electrical wires or other dangerous scenario, the first aider should be very careful not to rush into a situation, which may prove to be fatal.

Remember A-B-Cs

The ABCs of first aid refer to the three critical things the first aiders need to look for.

- Airway - Does the person have an unobstructed airway?
- Breathing - Is the person breathing?
- Circulation - Does the person show a pulse at major pulse points (wrist, carotid artery, groin)

Avoid moving the victim

Avoid moving the victim unless they are in immediate danger. Moving a victim will often make injuries worse, especially in the case of spinal cord injuries.

Call emergency services

Call for help or tell someone else to call for help as soon as possible. If alone in at the accident scene, try to establish breathing before calling for help, and do not leave the victim alone unattended.

Determine responsiveness

If a person is unconscious, try to rouse them by gently shaking and speaking to them.

If the person remains unresponsive, carefully roll them on the side (recovery position) and open his airway.

- Keep head and neck aligned.
- Carefully roll them onto their back while holding his head.
- Open the airway by lifting the chin. (Fig 1)



Look, listen and feel for signs of breathing

Look for the victim's chest to raise and fall, listen for sounds of breathing.

If the victim is not breathing, see the section below

- If the victim is breathing, but unconscious, roll them onto their side, keeping the head and neck aligned with the body. This will help drain the mouth and prevent the tongue or vomit from blocking the airway.

Check the victim's circulation

Look at the victim's colour and check their pulse (the carotid artery is a good option; it is located on either side of the neck, below the jaw bone). If the victim does not have a pulse, start CPR.

Treat bleeding, shock and other problems as needed

After establishing that the victim is breathing and has a pulse, next priority should be to control any bleeding. Particularly in the case of trauma, preventing shock is the priority.

- **Stop bleeding:** Control of bleeding is one of the most important things to save a trauma victim. Use direct pressure on a wound before trying any other method of managing bleeding.
- **Treat shock:** Shock, a loss of blood flow from the body, frequently follows physical and occasionally psychological trauma. A person in shock will frequently have ice cold skin, be agitated or have an altered mental status, and have pale colour to the skin around the face and lips. Untreated, shock can be fatal. Anyone who has suffered a severe injury or life-threatening situation is at risk for shock.

- **Choking victim:** Choking can cause death or permanent brain damage within minutes.
- **Treat a burn:** Treat first and second degree burns by immersing or flushing with cool water. Don't use creams, butter or other ointments, and do not pop blisters. Third degree burns should be covered with a damp cloth. Remove clothing and jewellery from the burn, but do not try to remove charred clothing that is stuck to burns.
- **Treat a concussion:** If the victim has suffered a blow to the head, look for signs of concussion. Common symptoms are: loss of consciousness following the injury, disorientation or memory impairment, vertigo, nausea, and lethargy.
- **Treat a spinal injury victim:** If a spinal injury is suspected, it is especially critical, not move the victim's head, neck or back unless they are in immediate danger.

Stay with the victim until help arrives

Try to be a calming presence for the victim until assistance can arrive.

Unconsciousness (COMA)

Unconscious also referred as Coma, is a serious life threatening condition, when a person lie totally senseless and do not respond to calls, external stimulus. But the basic heart, breathing, blood circulation may be still intact, or they may also be failing. If unattended it may lead to death.

The condition arises due to interruption of normal brain activity. The causes are too many.

- Shock (Cardiogenic, Neurogenic)
- Head injury (Concussion, Compression)
- Asphyxia (obstruction to air passage)
- Extreme of body temperature (Heat, Cold)
- Cardiac arrest (Heart attack)
- Stroke (Cerebro-vascular accident)
- Blood loss (Haemorrhage)
- Dehydration (Diarrohea & vomiting)
- Diabetes (Low or high sugar)
- Blood pressure (Very low or very high)
- Over dose of alcohol, drugs
- Poisoning (Gas, Pesticides, Bites)
- Epileptic fits (Fits)
- Hysteria (Emotional, Psychological)

The following symptoms may occur after a person has been unconscious:

- Confusion
- Drowsiness

- Headache
- Inability to speak or move parts of his or her body (see stroke symptoms)
- Light headedness
- Loss of bowel or bladder control (incontinence)
- Rapid heartbeat (palpitation)
- Stupor

First aid

- Call EMERGENCY number.
- Check the person's airway, breathing, and pulse frequently. If necessary, begin rescue breathing and CPR.
- If the person is breathing and lying on the back and after ruling out spinal injury, carefully roll the person onto the side, preferably left side. Bend the top leg so both hip and knee are at right angles. Gently tilt the head back to keep the airway open. If breathing or pulse stops at any time, roll the person on to his back and begin CPR.
- If there is a spinal injury, the victims position may have to be carefully assessed. If the person vomits, roll the entire body at one time to the side. Support the neck and back to keep the head and body in the same position while you roll.
- Keep the person warm until medical help arrives.
- If you see a person fainting, try to prevent a fall. Lay the person flat on the floor and raise the level of feet above and support.
- If fainting is likely due to low blood sugar, give the person something sweet to eat or drink when they become conscious.

DO NOT

- Do not give an unconscious person any food or drink.
- Do not leave the person alone.
- Do not place a pillow under the head of an unconscious person.
- Do not slap an unconscious person's face or splash water on the face to try to revive him.

Loss of consciousness may threaten life if the person is on his back and the tongue has dropped to the back of the throat, blocking the airway. Make certain that the person is breathing before looking for the cause of unconsciousness. If the injuries permit, place the casualty in the recovery position with the neck extended. Never give anything by mouth to an unconscious casualty.

Fig 2

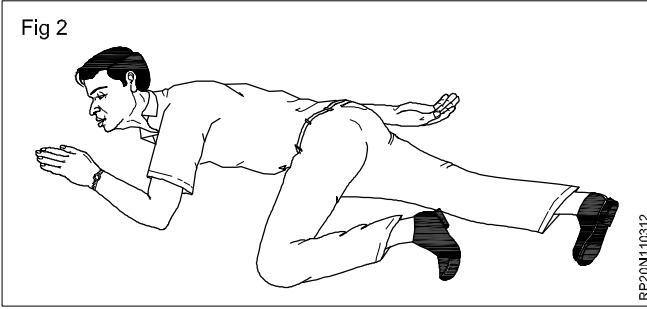

How to diagnose an unconscious injured person

- **Consider alcohol:** look for signs of drinking, like empty bottles or the smell of alcohol.
- **Consider epilepsy:** are there signs of a violent seizure, such as saliva around the mouth or a generally dishevelled scene?
- **Think insulin:** might the person be suffering from insulin shock (see 'How to diagnose and treat insulin shock')?
- **Think about drugs:** was there an overdose? Or might the person have under dosed - that is not taken enough of a prescribed medication?
- **Consider trauma:** is the person physically injured?
- **Look for signs of infection:** redness and/ or red streaks around a wound.
- **Look around for signs of Poison:** an empty bottle of pills or a snakebite wound.
- **Consider the possibility of psychological trauma:** might the person have a psychological disorder of some sort?
- Consider stroke, particularly for elderly people.
- Treat according to what you diagnose.

Shock (Fig 3)

A severe loss of body fluid will lead to a drop in blood pressure. Eventually the blood's circulation will deteriorate and the remaining blood flow will be directed to the vital organs such as the brain. Blood will therefore be directed away from the outer area of the body, so the victim will appear pale and the skin will feel ice cold.

Fig 3



Guidelines for good shop floor maintenance

Objectives: At the end of this lesson you shall be able to

- list the benefits of a shop floor maintenance
- state what is 5s
- list the benefits of 5s.

Benefits of a shop floor maintenance

Some of the benefits which may be derived from the utilization of a good Shop Floor Maintenance are as follows:

- Improved productivity
- Improved operator efficiencies.
- Improved support operations such as replenishment moves and transportation of work in process and finished goods.
- Reduction of scrap
- Better control of your manufacturing process
- More timely information to assist shop floor supervisors in managing their assigned production responsibilities.
- Reduction of down time due to better machine and tool monitoring.
- Better control of work in progress inventory, what is and where it is improved on time schedule performance.

5S concept

5S is a Japanese methodology for works place organisation. In Japanese it stands for seiri (SORT), seiton (SET), seiso (SHINE), seiketsu (STANDARDIZE) and shitsuke (SUSTAIN).

The list describes how to organize a work space for efficiency and effectiveness by identifying and storing the items used, maintaining the area and items, and sustaining the new order. The list describes how to organize a work space for efficiency and effectiveness by identifying and storing the items used. maintaining the area and items, and sustaining the new order.

5S Wheel (Fig 1)

The Benefits of the 5s system

- Increases in productivity
- Increases in quality
- Reduction in cost

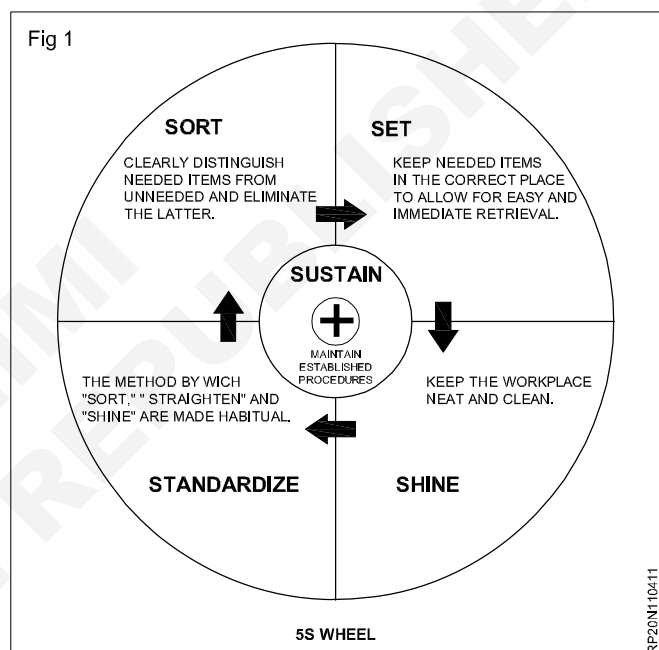

Importance of housekeeping

Objectives: At the end of this lesson you shall be able to

- list the steps involves in house keeping
- state good shop floor practices followed in industry

Housekeeping

The following activities to be performed for better up keep of working environment:

- 1 **Cleaning of shop floor:** Keep clean and free from accumulation of dirt and scrap daily
- 2 **Cleaning of Machines :** Reduce accidents to keep machines cleaned well
- 3 **Prevention of Leakage and spillage:** Use splash guards in machines and collecting tray
- 4 **Disposal of Scrap-** Empty scrap, wastage, swarf from respective containers regularly
- 5 **Tools Storage-** Use special racks, holders for respective tools
- 6 **Storage Spaces:** Identify storage areas for respective items. Do not leave any material in gangway
- 7 **Piling Methods-** Do not overload platform, floor and keep material at safe height.
- 8 **Material handling:** Use forklifts, conveyors and hoist according to the volume and weight of the package.

Good shop floor practices followed in industry

Good Shop floor practices are motivating action plans for improvement of the manufacturing process.

- All workers are communicated with daily target on manufacturing, activities.
- Informative charts are used to post production, quality and safety results compared to achievements.
- Workers are trained on written product quality standards.
- Manufactured parts are inspected to ensure adherence to quality standards.
- Production processes are planned by engineering to minimize product variation.
- 5s methods are used to organize the shop floor and production lines.
- Workers are trained on plant safety practices in accordance with Occupational Safety Health (OSH) standards.
- Workers are trained on "root cause" analysis for determining the causes of not following.
- A written preventive maintenance plan for upkeep of plant, machinery & equipment
- Management meets with plant employees regularly to get input on process improvements.
- Process Improvement Teams are employed to implement "best practices"

Disposal of waste material

Objectives: At the end of this lesson you shall be able to

- state what is waste material
- list the waste materials in a work shop
- explain the methods of disposal of waste material.
- state advantage of disposal of waste material.
- state colour code for bins for waste segregation.

Waste material

industrial waste is the waste produced by industrial activity such as that of factories, mills and mines.

List of waste material (Fig 1)

- Cotton waste
- Metal chips of different material.
- Oily waste such as lubricating oil, coolant etc.
- Other waste such electrical, glass etc.

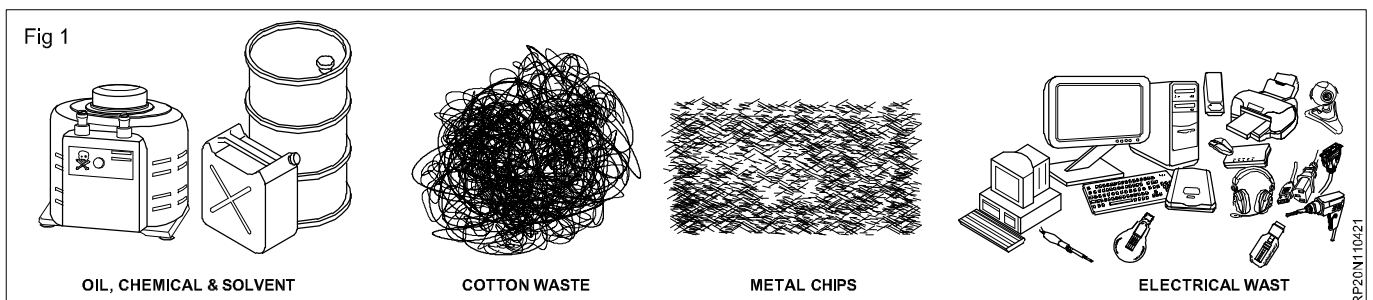

Methods of waste disposal

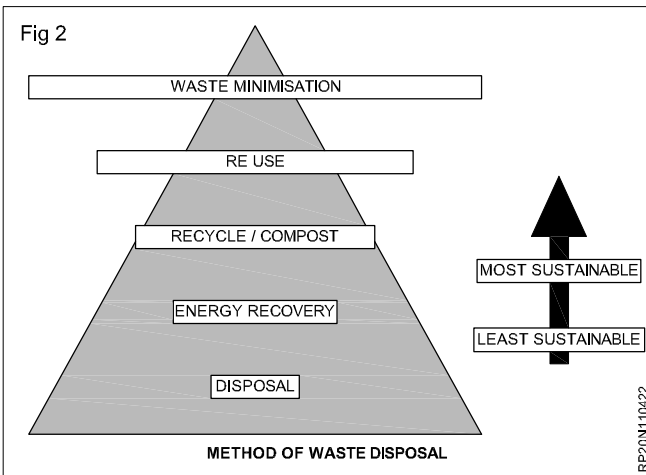

Recycling

Recycling is one of the most well known method of managing waste. It is not expensive and can be easily done by you. If you carry out recycling, you will save a lot of energy, resources and thereby reduce pollution.

Composting

This is a natural process that is completely free of any hazardous by-products. This process involves breaking down the materials into organic compounds that can be used as manure.

Landfills

Waste management through the use of landfills involves the use of a large area. This place is dug open and filled with the waste.

Burning the waste material

If you cannot recycle or if there are no proper places for setting up landfills, you can burn the waste matter generated in your household. Controlled burning of waste at high temperatures to produce steam and ash is a preferred waste disposal technique.

Advantage of waste disposal:

- Ensures workshop neat & tidy
- Reduces adverse impact on health
- Improves economic efficiency
- Reduce adverse impact on environment

Incineration (Fig.3)

It is the process of controlled combustion of garbage to reduce it to incombustible matter, ash, waste gas and heat. It is treated and released into the environment (Fig.3). This reduced 90% volume of waste, some time the heat generated used to produce electric power.

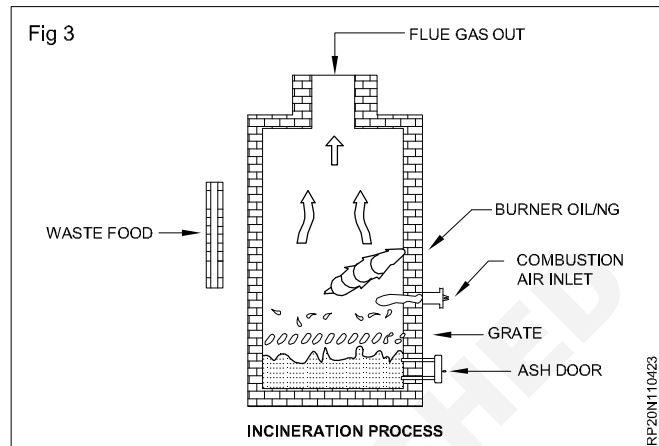

Waste compaction

The waste materials such as cans and plastic bottles compact into blocks and send for recycling. This process space need, thus making transportation and positioning easy.

Colour code for bins for waste segregation given in Table-1

Table-1

Sl.No.	Waste Material	Color code
1	Paper	Blue
2	Plastic	Yellow
3	Metal	Red
4	Glass	Green
5	Food	Black
6	Others	Sky blue

Occupational health and safety

Objectives: At the end of this lesson you shall be able to

- **define safety**
- **state the goal of occupational health and safety**
- **explain need of occupational health and safety**
- **state the occupational hygiene**
- **explain occupational hazards**
- **brief the occupational disease.**

Safety

Safety means freedom or protection from harm, danger, hazard, risk, accident, injury or damage.

Occupational health and safety

- Occupational health and safety is concerned with protecting the safety, health and welfare of people engaged in work or employment.
- The goal is to provide a safe work environment and to prevent hazards.
- It may also protect co-workers, family members, employers, customers, suppliers, nearby communities, and other members of the public who are affected by the workplace environment.
- it involves interactions among many related areas, including occupational medicine, occupational (or industrial) hygiene, public health, and safety engineering, chemistry, and health physics.

Need of occupational health and safety

- Health and safety of the employees is an important aspect of a company's smooth and successful functioning.
- It is a decisive factor in organizational effectiveness. It ensures an accident-free industrial environment.
- Proper attention to the safety and welfare of the employees can yield valuable returns.
- Improving employee morale
- Reducing absenteeism
- Enhancing productivity
- Minimizing potential of work-related injuries and illnesses
- Increasing the quality of manufactured products and / rendered services.

Occupational (Industrial) hygiene

- Occupational hygiene is anticipation, recognition, evaluation and control of work place hazards (or) environmental factors (or) stresses
- This is arising in (or) from the workplace.

- Which may cause sickness, impaired health and well being (or) significant discomfort and inefficiency among workers.

Anticipation (Identification): Methods of identification of possible hazards and their effects on health.

Recognition (Acceptance): Acceptance of ill-effects of the identified hazards

Evaluation (Measurement & Assessment): Measuring or calculating the hazard by Instruments, Air sampling and Analysis, comparison with standards and taking judgement whether measured or calculated hazard is more or less than the permissible standard.

Control of workplace hazards: Measures like Engineering and Administrative controls, medical examination use of Personal Protective Equipment (PPE) education, training and supervision.

Occupational hazards

"Source or situation with a potential for harm in terms of injury or ill health, damage to property, damage to the workplace environment, or a combination of these"

Types of occupational health hazards

- Physical Hazards
- Chemical Hazards
- Biological Hazards
- Physiological Hazards
- Psychological Hazards
- Mechanical Hazards
- Electrical Hazards
- Ergonomic Hazards

1 Physical hazards

- Noise
- Heat and cold stress
- Vibration
- Radiation (ionising & Non-ionising)
- Illumination etc.,

2 Chemical hazards

- Inflammable
- Explosive
- Toxic
- Corrosive
- Radioactive

3 Biological hazards

- Bacteria
- Virus
- Fungi
- Plant pest
- Infection

4 Physiological

- Old age
- Sex
- Ill health
- Sickness
- Fatigue.

5 Psychological

- Wrong attitude
- Smoking
- Alcoholism
- Unskilled
- Poor discipline
 - absentism
 - disobedience
 - aggressive behaviour

- Accident proneness etc,
- Emotional disturbances
 - violence
 - bullying
 - sexual harassment

6 Mechanical

- Unguarded machinery
- No fencing
- No safety device
- No control device etc.,

7 Electrical

- No earthing
- Short circuit
- Current leakage
- Open wire
- No fuse or cut off device etc,

8 Ergonomic

- Poor manual handling technique
- Wrong layout of machinery
- Wrong design
- Poor housekeeping
- Awkward position
- Wrong tools etc,

Safety Slogan

A safety rule breaker, is an accident maker

Safety Sign

Objectives: At the end of this lesson you shall be able to

- list three kinds of road sign
- describe the marking on the road
- describe the various police traffic hand signal and light signal
- list the collision causes.

In older days road locomotive carrying a red flag by day and red lantern by night. Safety is the prime motive of every traffic.

Kinds of road signs

Mandatory

Cautionary and

Informatory

Mandatory sign (Fig 1)

Violation of mandatory sign can lead to penalties. Ex. Stop, give way limits, prohibited, no parking and compulsory sign.

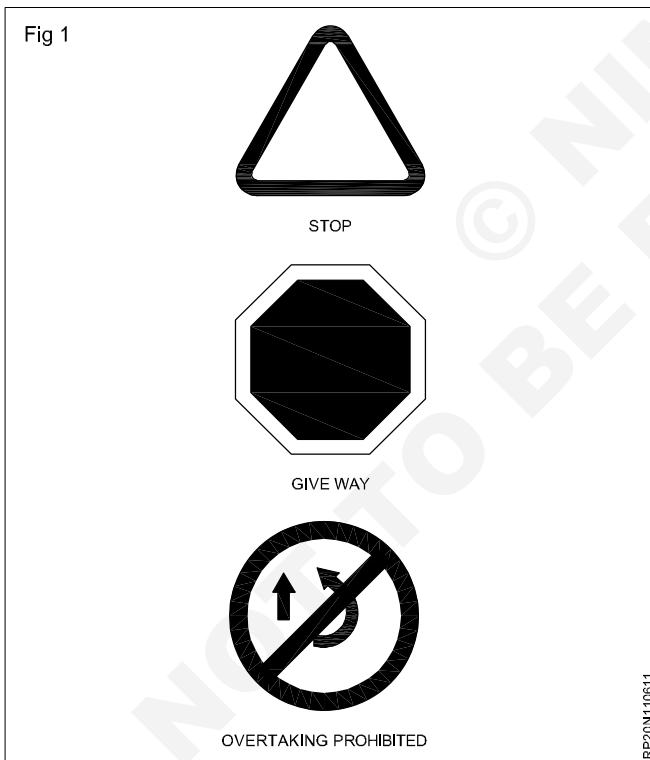

Cautionary signs (Fig 2)

Cautionary/ warning signs are especially safe. Do's and don'ts for pedestrians, cyclists, bus passengers and motorists.

Information signs (Fig 3)

Information signs are especially benefit to the passengers and two wheelers.

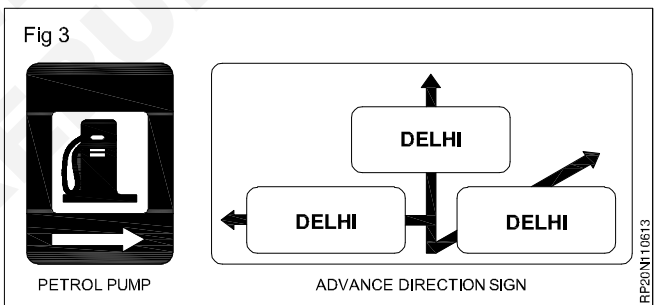
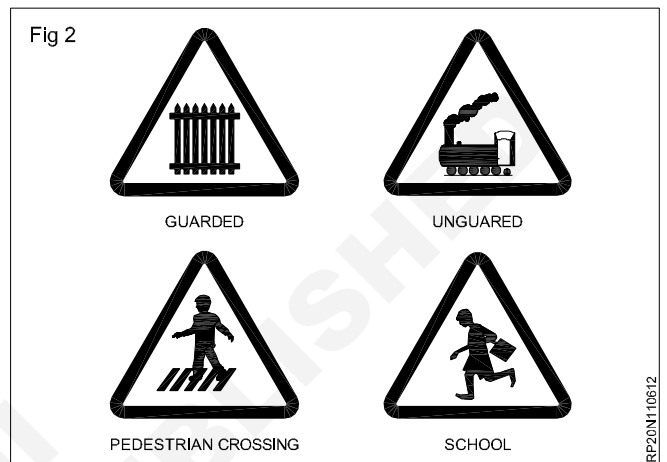

Marking lines on road (Fig 4)

- Marking lines are directing or warn to the moving vehicles, cyclist and pedestrians to follow the law.
- Single and short broken lines with middle of the road allow the vehicle to cross the dotted lines safely overtake whenever required.
- When moving vehicle approaching pedestrian crossing, be ready to slow down or stop to let people cross.
- Do not overtake in the vicinity of pedestrain crossing.

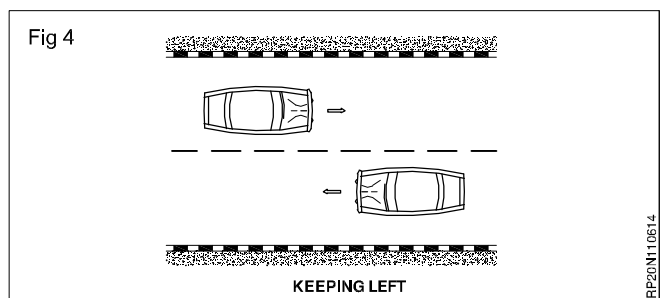

Police signals

To stop a vehicle approaching from behind. Fig 5(1)

To stop a vehicle coming from front. Fig 5(2)

To stop vehicles approaching simultaneously from front and behind. Fig 5(3)

To stop traffic approaching from left and wanting to turn right. Fig 5(4)

To stop traffic approaching from the right to allow traffic from left turn right. Fig 5(5)

To allow traffic coming from the right and turning right by stopping traffic approaching from the left. Fig 5(6)

Warning signal closing all traffic. Fig 5(7)

Beckoning on vehicles approaching from left. Fig 5(8)

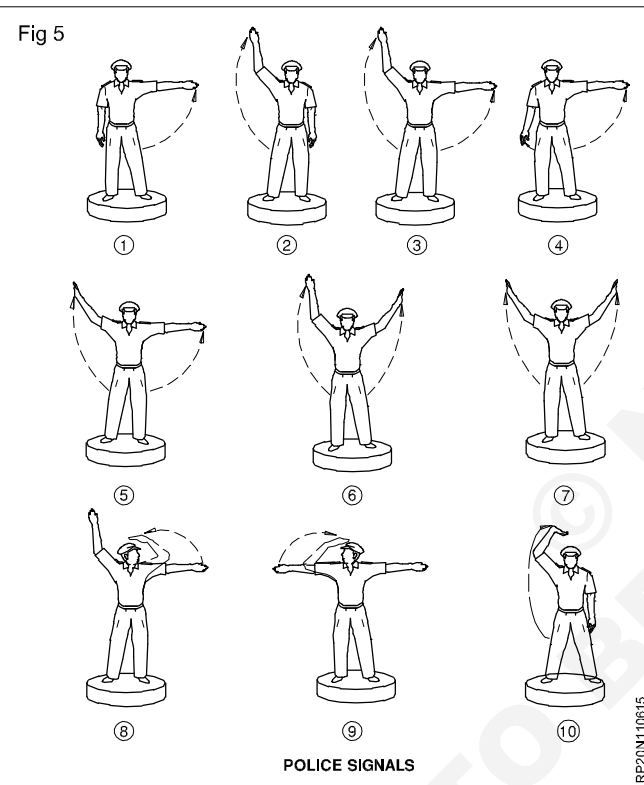

Beckoning on vehicles approaching from right. Fig 5(9)

Beckoning on vehicles from front. Fig 5(10)

Traffic light signals

Red means stop. Wait behind the stop line on the carriage way. Fig 6(1)

Red and amber also means stop. Do not pass through or start until green shows. Fig 6(2)

Green means you may go on if the way is clear. Take special care if you mean to turn left or right and give way to pedestrians who are crossing. Fig 6(3)

Amber means stop at the stop line. you may only go on if the amber appears after you have crossed the stop line or so close to it that to pull up may not be possible. Fig 6(4)

Green arrow means that you may go in the direction shown by the arrow. You may do this whatever other lights may be showing. Fig 6(5)

Pedestrians - do not cross. Fig 6(6)

Pedestrians - cross now. Fig 6(7)

Flashing red means stop at the stop line and if the way is clear proceed with caution. Fig 6(8)

Flashing amber means proceed with caution. Fig 6(9)

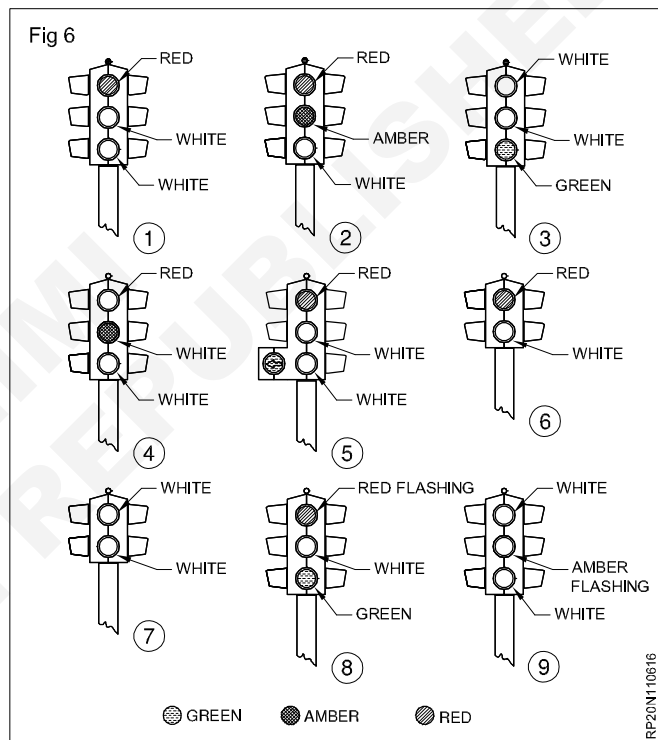

Collision causes

Three factors are responsible for collision

- Roads
- Vehicles and
- Drivers.

The fig 7 shows approximately proportionate causes of collision. In wrong attitudes such that avoid foolish acts at the wheel. Driving time is not play time. (Fig 8)

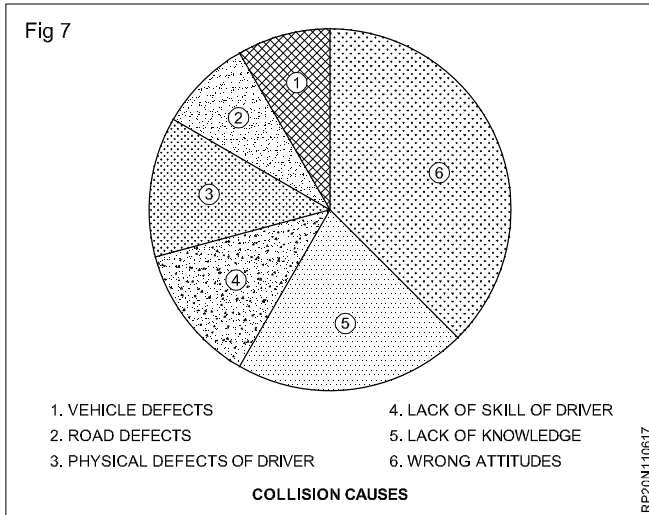

Safety practice

Objectives : At the end of this lesson you shall be to

- state the responsibilities of employer and employees
- state the safety attitude and list the four basic categories of safety signs.

Safety

The state of being safe, freedom from the occurrence or risk of injury, danger or loss.

Responsibilities

Safety doesn't just happen - it has to be organised and achieved like the work-process of which it forms a part. The law states that both an employer and his employees have a responsibility in this behalf.

Employer's responsibilities

The effort a firm puts into planning and organising work, training people, engaging skilled and competent workers, maintaining plant and equipment, and checking, inspecting and keeping records - all of this contributes to the safety in the workplace.

The employer will be responsible for the equipment provided, the working conditions, what the employees are asked to do, and the training given.

Employee's responsibilities

You will be responsible for the way you use the equipment, how you do your job, the use you make of your training, and your general attitude to safety.

A great deal is done by employers and other people to make your working life safer; but always remember you are responsible for your own actions and the effect they have on others. You must not take that responsibility lightly.

Rules and procedure at work

What you must do, by law is often included in the various rules and procedures laid down by your employer. They

may be written down, but more often than not, are just the way a firm does things - you will learn these from other workers as you do your job. They may govern the issue and use of tools, protective clothing and equipment, reporting procedures, emergency drills, access to restricted areas, and many other matters. Such rules are essential and they contribute to the efficiency and safety of the job.

Safety signs

As you go about your work on a construction site you will see a variety of signs and notices. Some of these will be familiar to you - a 'no smoking' sign for example; others you may not have seen before. It is up to you to learn what they mean - and to take notice of them. They warn of the possible danger, and must not be ignored.

Safety signs fall into four separate categories. These can be recognised by their shape and colour. Sometimes they may be just a symbol; other signs may include letters or figures and provide extra information such as the clearance height of an obstacle or the safe working load of a crane.

The four basic categories of signs are as follows:

- prohibition signs (Fig 1 & Fig 5)
- mandatory signs (Fig 2 & Fig 6)
- warning signs (Fig 3 & Fig 7)
- information signs (Fig 4)

Prohibition signs

Fig 1

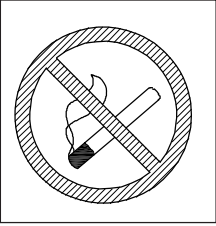
	SHAPE	Circular.
	COLOUR	Red border and cross bar. Black symbol on white background
	MEANING	Shows it must not be done.
	Example	No smoking

Mandatory signs

Fig 2

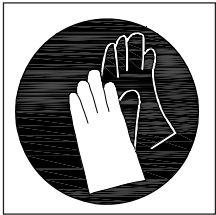
	SHAPE	Circular.
	COLOUR	White symbol on blue background
	MEANING	Shows what must be done
	Example	Wear hand protection

Warning signs

Fig 3

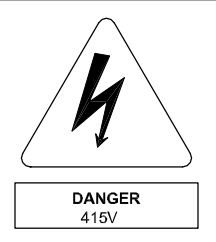
	SHAPE	Triangular
	COLOUR	Yellow background with black border and symbol.
	MEANING	Warns of hazard or danger.
	Example	Caution, risk of electric shock.

Information signs

Fig 4

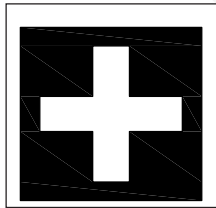
	SHAPE	Square or oblong.
	COLOUR	White symbols on green background.
	MEANING	Indicates or gives information of safety provision.
	Example	First aid point.

Prohibition signs

Fig 5

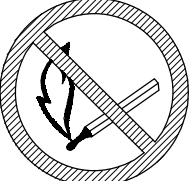
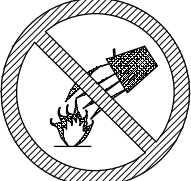
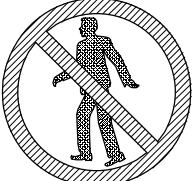
		
SMOKING AND NAKED FLAMES PROHIBITED	DO NOT EXTINGUISH WITH WATER	PEDESTRIANS PROHIBITED

RP20N110625

Mandatory signs

Fig 6

		
WEAR HEAD PROTECTION	WEAR EYE PROTECTION	WEAR HEARING PROTECTION
		
WEAR FOOT PROTECTION	WEAR HAND PROTECTION	WEAR RESPIRATOR
		
WEAR SAFETY HARNESS/BELT	USE ADJUSTABLE GUARD	WASH HAND

MANDATORY SIGNS

RP20N110626

Warning signs

Fig 7

		
RISK OF FIRE	RISK OF ELECTRIC SHOCK	TOXIC HAZARD
		
CORROSIVE SUBSTANCES	RISK OF IONIZING RADIATION	LASER BEAM
		
RISK OF EXPLOSION	OVERHEAD HAZARD (FIXED HAZARD)	GENERAL WARNING RISK OF DANGER
		
OVERHEAD LOAD	FRAGILE ROOF	FORK LIFT TRUCK

WARNING SIGNS

RP20N110627

Question about your safety

Do you know the general safety rules that cover your place of work?

Are you familiar with the safety laws that govern your particular job?

Do you know how to do your work without causing danger to yourself, your workmates and the general public?

Are the plant, machinery and tools that you use really safe? Do you know how to use them safely and keep them in a safe condition?

Do you wear all the right protective clothing, and have you been provided with all the necessary safety equipment?

Have you been given all the necessary safety information about the materials used?

Have you been given training and instruction to enable you to do your job safely?

Do you know who is responsible for safety at your place of work?

Do you know who are the appointed 'Safety Representatives'?

Response to emergencies - Power failure, System failure & Fire

Objectives: At the end of this lesson you shall be able to

- state the reason of emergency power failure
 - state the cause of system failure
 - state the fire safety and immediate actions.
-

1 If there is a power failure, start the emergency generator. This provides power to close the shutter, which is the first priority. The generator will also keep the UPSs and the cryogenic compressors running,

- Get a flash light.
- Look out for power transfer switch and switch over to normal power to emergency power by pressing the latch.
- Check the fuel valves open or not - Open the valves.
- Check to see that the main breaker switch ON the generator is in OFF position.
- Move the starter switch of the generator to run position. The engine will start at once.
- Allow few minutes to warm up the engine.
- Check all the gauges, pressure, temperature, voltage and frequency.
- Check the "AC line" and "Ready" green light on the front panel.

2 System failure

- If the bug or virus, invades the system. The system failure happens.

- Several varieties of bugs are there

1. Assasin bug
2. Lightning bug
3. Brain bug

For more details refer instruction manual for "System failure".

3 Fire failure

When fire alarm sounds in your buildings

1. Evacuate to outside immediately.
2. Never go back
3. Make way for fire fighters and their trucks to come
4. Never use an elevator
5. Do not panic

Reporting emergency

Objectives : At the end of this lesson you shall be able to

- explain the report an emergency
 - report through emergency services.
-

Report an emergency

Reporting an emergency is one of those things that seems simple enough, until actually when put to use in emergency situations. A sense of shock prevail at the accident sites. Large crowd gather around only with inquisitive nature, but not to extend helping hands to the victims. This is common in road side injuries. No passer by would like to get involved to assist the victims. Hence first aid managements is often very difficult to attend to the injured persons. The first aiders need to adapt multitask strategy to control the crowd around, communicate to the rescue

team, call ambulance etc, all to be done simultaneously. The mobile phones helps to a greater deal for such emergencies. Few guidelines are given below to approach the problems.

Assess the urgency of the situation. Before you report an emergency, make sure that the situation is genuinely urgent. Call for emergency services if you believe that a situation is life-threatening or otherwise extremely disruptive.

- A fire - If you're reporting a fire, describe how the fire started and where exactly it is located. If someone has already been injured, missing, report that as well.
- A life - threatening medical emergency, explain how the incident occurred and what symptoms the person currently displays.

Call emergency service

The emergency number varies - 100 for Police & Fire, 108 for Ambulance.

Report your location

The first thing the emergency dispatcher will ask where you are located, so the emergency services can get there as quickly as possible. Give the exact street address, if you're not sure of the exact address, give approximate information.

© NIMI
NOT TO BE REPUBLISHED

Importance of adopting a “safety attitude” when is flying a RPA

Objectives: At the end of this lesson you shall be able to

- description of workshop safety norms
 - explanation of outdoor flight safety regulations
 - interpretation of DGCA Regulations
 - define classification of CAR
 - state Basic Air Regulation
 - description of the main points
 - knowledge of Do's and Don'ts.
-

Generally, drone crash does not happen; they are caused.

Most accidents are avoidable if we adopt safe attitude. A drone pilot must have

Calm attitude, and positive attitude. A drone pilot should not have these 5 hazardous attitudes: Macho, Invulnerability, Anti-authority, Impulsivity, Resignation

Advantage of adopting safety altitude

- Drone will be safe
- Easy to handle
- Prevent from loss of link
- Drone will be green zone
- Safe other people & properties

Workshop safety norms

- 1 Listen carefully to the instructor and follow instructions.
- 2 Ask questions, especially if you do not fully understand.
- 3 Do not touch a drone, if you have not been shown how to operate it safely, by your teacher.
- 4 Always be patient, never rush practical work.
- 5 Always use precaution, when operating drone.
- 6 Keep hands / hair and clothing away from moving/ rotating parts of drone.
- 7 Report any damage / faults to machines/equipment. Damage or a faulty part, could cause an accident.

Points to Remember Before Flying

- Do a Preflight inspection.
- Register your Drone/RPA before you fly outdoors.
- Fly below / as per DGCA norms.
- If you fly with a local club, fly according to your aeromodelling community based safety guidelines.
- Though not required, try to take lessons before you fly.
- Fly within line-of-sight of your RPA.
- Don't fly near manned aircraft.

Outdoor Drone Safety Tips**Follow local drone rules and regulations****Create a safe flying environment**

Choose an open flying zone and never fly above or around people or moving ground or air vehicles.

Configure outdoor failsafe

Properly set home location and safety perimeter.

Follow your pre-flight checklist

Ensure your drone is damage free and ready to fly

DGCA

The Directorate General of Civil Aviation (DGCA) is the regulatory body in the field of Civil Aviation, primarily dealing with safety issues. It is responsible for regulation of air transport services to/from/within India and for enforcement of civil air regulations, air safety, and airworthiness standards. The DGCA also coordinates all regulatory functions with the International Civil Aviation Organization (ICAO)

Directorate General of Civil Aviation (DGCA)- Key Functions

- 1 Registration of civil aircraft.
- 2 Formulation of standards of airworthiness for civil aircraft registered in India and grant of certificates of airworthiness to such aircraft.
- 3 Licensing of pilots, aircraft maintenance engineers and flight engineers, and conducting examinations and checks for that purpose.
- 4 Licensing of air traffic controllers.
- 5 Conducting an investigation into accidents/incidents and taking accident prevention measures including formulation of implementation of Safety Aviation Management programs.
- 6 Coordination at the national level for flexi-use of air space by civil and military air traffic agencies and interaction with ICAO for provision of more air routes for civil use through Indian air space.
- 7 Promoting indigenous design and manufacture of aircraft and aircraft components by acting as a catalytic agent.

- 8 Approving training programs of operators for carriage of dangerous goods, issuing authorizations for carriage of dangerous goods, etc.

Civil aviation includes three major categories:

1. Commercial air transport, including scheduled and non-scheduled passenger and cargo flights.
2. Aerial work, in which an aircraft is used for specialized services such as agriculture, photography, surveying, search and rescue, etc.
3. General aviation (GA), including all other civil flights, private or commercial.

Rule of Air

Rule of the air applies to all the aircraft flying over the Indian territory and other states as well provided that they do not conflict with the rules of that state contact appropriate ATS

Salient Points of CARs

Salient points of the above document have been summarised in the following part.

- 1 For the purposes of CAR, the RPAS have been grouped into five categories namely, Nano (250 gm or less), Micro (250 gm-2 kg), Mini (2 kg-25 kg), Small (25-150 kg) and Large (greater than 150 kg).
- 2 Any of the above RPAS can be imported (with due import clearance) or locally purchased. In either case, there will be a requirement to obtain Equipment Type Approval from the Wireless Planning and Coordination Wing of the Department of Telecommunication for operation in the de-licensed frequency band(s). This approval is not required for the Nano category of RPAS.
- 3 Except for three categories of RPAS which are exempted, namely, Nano RPAS operating below 50 ft in uncontrolled airspace or enclosed premises, Micro RPAS operating below 200 ft in enclosed premises, or RPAS operated by National Technical Research Organisation, Aviation Research Centre and Central intelligence agencies, all others will require a Unique Identification Number (UIN) which will be issued by the DGCA upon processing of their applications online for which a 'Digital Sky Platform' has been created.
- 4 UIN can only be granted to a citizens of India, Central and State Governments, an Indian company (registered/Indian Chairman/two-third stakes etc.) or a foreign company having leased RPAS to an Indian registered company. In addition to the UIN, RPAS, leaving out the exempted categories as stated above, will also require to obtain an Unmanned Aircraft Operator Permit (UAOP) from DGCA with a validity for five years for flying in the Indian civil airspace.
- 5 CARs lay down adequate instructions for safety and security as per a detailed programme prepared by Bureau of Civil Aviation Security. Aspects like reporting losses, damage to machines, accidents,

preventing sabotage of ground station etc., have been covered. An important provisions is that once a UIN has been issued, the RPAS cannot be destroyed or disposed off in any manner or transferred to a third party without informing the DGCA.

- 6 CARs also stipulate the requirement of training of the operators (except for the category exempted above) through the DGCA approved Flying Training Organisation. Minimum age stipulation of 18 years and minimum education standard of 10th class pass (with English) is stipulated for a RPAS pilot.
- 7 The main portion of the CARS are the Operating Requirements which are laid down as a Standard Operating Procedure. Some of these include only day light flying within visual line of sight, minimum visibility of 5 km, cloud ceiling not less than 450 m, surface winds not more than 10 knots and no precipitation conditions (rain, hail, snow) etc.
- 8 All RPAS except for Nano operating below 50 ft in uncontrolled airspace or enclosed premises and Micro RPAS operating below 200 ft, have to file the flight plan 24 hours in advance and obtain ATC briefing, Air Defence Clearance and Flight Information Centre number. In addition, local Police Headquarters needs also to be informed.
- 9 CARs also lay down detailed operating restrictions by specifying the areas where the RPAS cannot be flown. These include an area of 5 km from an airport or within permanent or temporary prohibited, restricted or danger areas as notified by the Aviation Authority of India (AAI), or without prior approval over densely populated areas, or over or near an area affecting public safety, or where emergency operations are underway, within 50 km of the international borders and beyond 500 metre (horizontal) into the sea along the coastline, within a 5 km radius from Vijay Chowk in New Delhi and from a mobile platform such as a moving vehicle, ship or aircraft. RPAS are restricted from carrying out aerial photography or remote sensing surveys over restricted areas unless specific permission is granted on case-to-case basis.
- 10 In addition, the CARs also lays down minimum standards for manufacturing of RPAS, legal obligations on the operators for any damage or prejudice caused to property or persons, requirement of third party insurance and enforcement actions against violators by way of cancellation of UIN and UAOP, besides penal actions of penalties under various sections of Indian Penal Code, and the Aircraft Rules 1934 and 1937.

Do's

Ensure your Drone (except Nano in uncontrolled airspace upto 50ft) is Digital Sky "No Permission- No Take off" (NPNT) Compliant.

- Obtain Unique Identification Number (UIN) from DGCA for operating in controlled airspace and affix it on your drone. Obtain Unmanned Aircraft Operator Permit (UAOP), if applicable from DGCA for commercial operations and keep it handy.

- Obtain Permission before each flight through Digital Sky Platform.
- Ensure drone is in good condition (not damaged) and fit for flying safely.
- Keep an eye on interference: Interference can be from mobile devices or blockage of signals, do watch out when flying your drone.
- Fly only during daylight (after sunrise to before sunset).
- Fly in good weather: Good weather lets you not only fly your drone better but also keep track of it in the air.
- Fly in visual line of sight (VLOS): Always be within visual range of your drone.
- Follow Flying Guidelines.
- Do your homework before spending the considerable money for a drone. Make sure you clearly understand all operational and regulatory aspects.
- Be aware of Airspace Restrictions/ No Drone Zones.

Do stay away from airports and heliports.

Respect privacy of people.

Keep local police informed about your drone flying activity. If you are ever approached by police provide all requisite information.

Do log your flights and intimate concerned authorities (like DGCA, local police etc) of any incidents/accidents.

Don'ts

- Don't fly a Nano drone above 50ft (15m) from the ground level.
- Don't fly a Micro drone above 200ft (60m) from the ground level.
- Don't fly drones more than 400ft (120m) from the ground level.
- Don't fly drone near other aircraft (manned or unmanned).
- Don't fly drone near airports and heliports.
- Don't fly drone over groups of people, public events, or stadiums full of people without permission
- Don't fly drone over government facilities/military bases or over/ near any no-drone zones.
- Don't fly drone over private property unless permission is given.
- Don't fly drone in controlled airspace near airports without filing flight plan or AAI/ADC permission (at least 24 hours before actual operation).
- Don't drop or carry hazardous material.
- Don't fly drone under the influence of drugs or alcohol.

- Don't fly drone from a moving vehicle, ship or aircraft Encounters of drone pilots including airfields, traffic patterns, etc.

Drone pilots face a lot of difficulties in airspace and air traffic. The number of drones is increasing day by day which creates problem in drone flight which leads to more air traffic.

Understanding ATC Operations Airspace and Airspace Restrictions

With the idea of No RPA Zone

Airspace map

The Airspace map is dynamic in nature. Please check the zone restrictions before every drone flight through digital sky platform

Controlled Airspace

Controlled airspace is a generic term that covers the different classifications of airspace and defined dimensions within which ATC service is provided in accordance with the airspace classification. Controlled airspace consists of:

- Class E
- Class D
- Class C
- Class B
- Class A

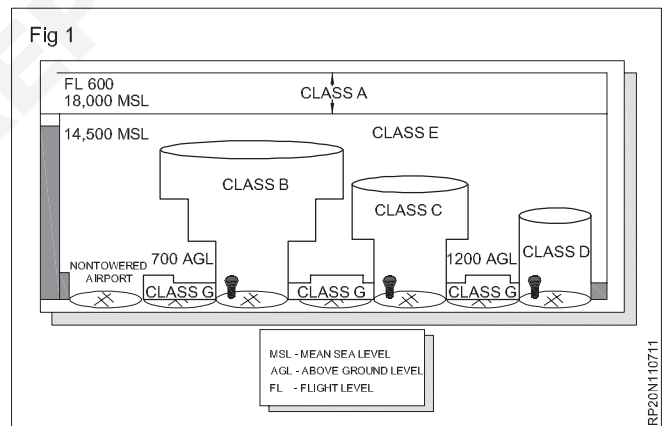

Class G Airspace

Class G or uncontrolled airspace is the portion of the airspace that ATC service is not provided

There are no communications, entry, equipment, or minimum pilot certificate requirements to fly in uncontrolled Class G airspace unless there is a control tower.

Restricted airspace

Restricted airspace is an area of airspace typically used by the DGCA in which the local controlling authorities have determined that air traffic must be restricted or prohibited for safety or security concerns.

No Drone Zones

Drones are not allowed in some specified areas "No Fly Zones" flying a drone is restricted by government regulations.

Operating restrictions

Restricted areas	Range
Near airports	From the perimeter of a distance of 5 km
Any civil, private or defence airports,	A distance of 3 km from the perimeter of
Above Obstacle Limitation Surfaces (OLS) or PANS-OPS surfaces, whichever is lower, of an operational aerodrome,	
Prohibited, prohibited and hazardous zones, like TRA, permanent or temporary, and TSA	
Line of Control (LoC), Line of Actual Control (LAC) and Actual Land Location Line (AGPL) from the international boundary	Within 25km
sea from coast line	Beyond 500 m (horizontal)
Military Installations/ Facilities/ where military activities/ exercises are being carried out unless clearance is obtained from the local military installation/ facility;	Within 3 km from perimeter of
Vijay Chowk in Delhi	Within 5 km radius from
strategic locations/ vital installations notified by Ministry of Home Affairs	Within 2 km from perimeter of
Listed by the Ministry of Environment, Forests and Climate Change on eco-sensitive areas around National Parks and Wildlife Sanctuaries	
From a mobile platform, including a ship, aircraft or a moving vehicle.	
State Secretariat Complex in State Capitals;	Within 3 km from radius of

Communicating with ATC And mention Position and Altitude Report

Reports should include the following items:

- 1 Identification
- 2 Position
- 3 Time
- 4 Altitude or flight level (include actual altitude or flight level when operating on a clearance specifying VFR-on-top)
- 5 Type of flight plan (not required in IFR position reports made directly to ARTCCs or approach control)
- 6 ETA and name of next reporting point
- 7 The name only of the next succeeding reporting point along the route of flight; and
- 8 Pertinent remarks

Procedures for the submission of a flight plan

Flight plans submitted in hard copy for scheduled flights via any electronic media available from ATS authorities will be accepted.

Flight plans can be submitted online by the captain after registration or opening an account at the Airports Authority of India website www.aai.aero.

A flight plan contains such of the following information as is relevant to the flight:

- Aircraft identification
- Flight rules and type of flight
- Number and type(s) of aircraft and wake turbulence category
- Equipment
- Departure aerodrome
- Estimated off-block time
- Cruising speed
- Cruising level
- Route to be followed
- Destination aerodrome and total estimated elapsed time
- alternate aerodrome
- Fuel endurance
- Total number of persons on board
- Emergency and survival equipment
- Other information

Collision avoidance

Sense-and-avoid systems permits unmanned craft to autonomously find a potential collision with another craft and take evasive action, even as an individual's pilot would.

Various teams square measure operating to develop reliable sense-and-avoid systems which will match the detect-and-avoid capability of an individuals.

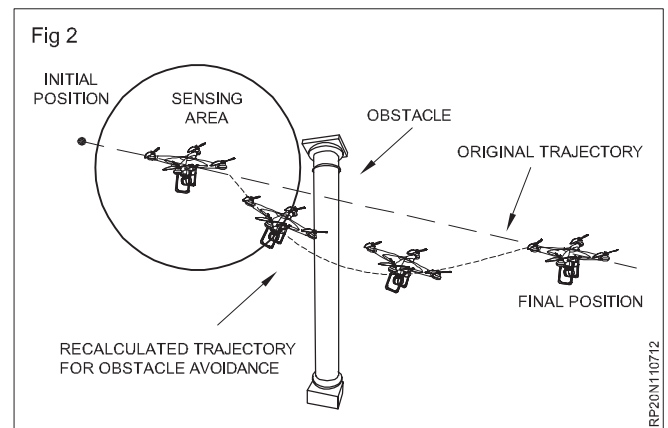

Radio Telephony (RT) techniques Standard radio terminology and RT Phraseology

Objectives: At the end of this lesson you shall be able to

- get Radio Telephony (RT) Technologies
- define standard radio vocabulary
- check out the RT Vacancies
- define radio communication.

Radio Telephony (RT) techniques

A radio telephone (or radio telephone) is a radio communication device for radio-based voice transmission. In relation to radiotelegraphy, which is the transmitting of telegraph signals, or broadcasting, the transmission of moving images and sound, radiotelephony means the transmission of sound (audio) by telephone.

Radio Telephone Alphabet

Letter	Code Word	Pronunciation
A	Alpha	(al fah)
B	Bravo	(brahvoh)
C	Charlie	(char lee)
D	Delta	(deltah)
E	Echo	(eck oh)
F	Foxtrot	(foks trot)
G	Golf	(golf)
H	Hotel	(ho tell)
I	India	(in dee ah)
J	Juliett	(joe lee ett)
K	Kilo	(keyloh)
L	Lima	(leemah)
M	Mike	(mike)
N	November	(november)
O	Oscar	(osscah)
P	Papa	(pahpah)
Q	Quebec	(qwa beck)
R	Romeo	(row me oh)
S	Sierra	(see air rah)
T	Tango	(tang go)

U	Uniform	(younee form)
V	Victor	(vik tor)
W	Whiskey	(wis key)
X	X-ray	(ecks ray)
Y	Yankee	(yangkee)
Z	Zulu	(zoo loo)

Numerals

Radiotelephony pronunciation of numbers shall be in the phonetic form as follows:

0	ZE-RO
1	WUN
2	TOO
3	TREE
4	FOW er
5	FIFE
6	SIX
7	SEV en
8	AIT
9	NIN er
Decimal	DAY SEE MAL
Hundred	HUN dred
Thousand	TOU SAND

Standard Radio Terminology

Procedure terms are traditional, readily pronounced words that have been given special meanings to speed up the handling of messages on radio networks. Whenever needed, they should be used. In order to ensure continuity in RTF (radiotelephony) communication, phraseology is the way to communicate between the pilot and the air traffic controller (ATC unit).

For general usage, the following procedural words are acceptable:

Word	Meaning
Acknowledge	Let me know that you have received and understood the message
Affirm	Yes
Approved	Permission for proposed action granted
Break	I hereby indicate the separation between portions of the message (to be used where there is no clear distinction between the text and other portions of the message)
Break break	I hereby indicate separation between messages transmitted to different aircraft in a very busy environment
Cancel	Annul the previously transmitted clearance
Check	Examine a system or procedure (no answer is normally expected)
Cleared	Authorised to proceed under the conditions specified
Confirm	Have you correctly received the following...?
	Did you correctly receive this message?
Contact	Establish radio contact with...
Correct	That is correct
Correction	An error has been made in this transmission (or message indicated). The correct version is...
Disregard	Consider that transmission as not sent
How do you read	What is the readability of my transmission? The readability scale is:
	1 Unreadable
	2 Readable now and then
	3 Readable but with difficulty
	4 Readable
5 Perfectly readable	
I say again	Repeat for clarity or emphasis
Correct	That is correct
Maintain	Continue in accordance with the condition(s) specified, or in its literal sense, for example: 'Maintain VFR'.
Mayday	My aircraft and its occupants are threatened by grave and imminent danger and/or I require immediate assistance
Monitor	Listen out on (frequency)
Negative	No Permission is not granted, That is not correct
	Permission is not granted, That is not correct
Out	My transmission is ended and I expect a response from you (not normally used in VHF communication)
Pan pan	I have an urgent message to transmit concerning the safety of my aircraft, or other vehicle or of some person on board, or within sight, but I do not require immediate assistance
Readback	Repeat all, or the specified part, of this message back to me exactly as received
Recleared	A change has been made to your last clearance and this new clearance supersedes your previous clearance or part thereof
Report	Pass me the following information
Request	Should like to know or I wish to obtain
Roger	I have received all of your last transmission
Say again	Repeat all or the following part of your last transmission
Speak slower	Reduce your rate of speech
Standby	Wait and I will call you
Verify	Check and confirm with originator
Wilco	Understand your message and will comply with it

Experience in Radio Communications.

Practice Radio telephony using Standard radio terminology

- 1 Practice the Radiotelephony with another trainee you can find.
- 2 Have your pen ready to write down information given to you
- 3 Don't hold the microphone tightly
- 4 Don't take shortcuts, but do be as concise as possible.
- 5 Try to relax, if you are stressed you will easily confuse what is said to you.

- 6 Don't abbreviate.
- 7 Listen before you transmit.
- 8 Think before keying your transmitter. Know what you want to say peak in a normal, conversational tone.
- 9 Be alert to the sounds or the lack of sounds in your receiver.
- 10 Be sure that you are within the performance range of your radio equipment and the ground station equipment.

For the RT practical, instructor explain all about RT procedures, trainee should go for proper understanding of the processes involved, and also be in good RT practice in general with phraseology.

Weather and meteorology: The standard atmosphere

Objectives: At the end of this lesson you shall be able to

- range of standard atmosphere
- determination of air pressure, heat and temperature, wind, humidity, cloud formation
- defined the Met Terminal Aviation Teen Weather Report (METAR).

The standard atmosphere

Weather is referring to the atmospheric condition of a specific place at a specific time, it change day to day and frequently. Example: Cloudy Weather, Foggy Weather, Rainy Weather etc.

While the term climate refers the average weather conditions over a large area for a long period of time, it doesn't change day to day and frequently. Example: Oceanic Climate, polar climate, rainforest etc.

What is Atmosphere?

Envelop of air is known as the atmosphere, an atmosphere is a layer or a set of different layers of gases surrounding a planet.

Different Layers of Atmosphere

Our Atmosphere divided on different types of layers; every layer contains different kind of properties.

Troposphere

The lower part of the Earth's atmosphere is the troposphere. We are living in the troposphere. The height of the troposphere varies from 9 km on average at the poles to 17 km at the Equator.

Stratosphere

The second layer of the Earth's atmosphere is the stratosphere. The stratosphere stretches from 10 km above the earth to a height of 50 km.

Mesosphere

A mesosphere is the next stage of the atmosphere of the Earth. This stretches from about 50 to 85 km above our earth. The temperature in the entire mesosphere decreases with height.

Thermosphere

The thermosphere in the Earth's atmosphere is the fourth layer. Ultraviolet radiation causes photoionization / photodissociation of molecules within this layer of the atmosphere, producing ions in the ionosphere. It ranges from around 90 km above our earth to between 500 and 1,000 km.

Exosphere

The exosphere is a thin outermost layer of the Earth's atmosphere, an atmosphere-like volume that surrounds a planet or a natural satellite where gases are gravitationally bound to the body, but where the mass is too low to interfere with each other to act as a gas. It ranges from an altitude of about 500kilometres and continues to about 10,000 kilometres

Fig 1



Measuring air pressure, heat and temperature, wind, humidity, cloud formation

The system should have a portable mechanical structure with all the sensors attached. LCD Display for real time data monitoring and USB interface for local storage and GSM connectivity for cloud storage,

Application Software for Dashboard for real time and remote monitoring and analysis.

Take the weather meter and go to the field, switch on the weather meter which has internal sensors that detect the values

Value in weather meter

Atmospheric Pressure Range: 15- 115kPa

Wind Direction Sensor: North, East, West, South, North-East, East-South, North-West, South-West

Wind Speed Sensor Speed: 0 to 20m/s

Air Temperature: 0°C to 100°C

Relative Humidity: 0% to 100 %RH

Solar Radiation Range: 0 to 2000W/m²

Air Quality Sensor (PM2.5): 10 - 500

Rainfall: Tipping bucket in mm

Cloud Formation:-

Clouds a formed when moist and warm air raises and expand in the atmosphere, water vapor condenses into small pieces of dust which come together to form a cloud.

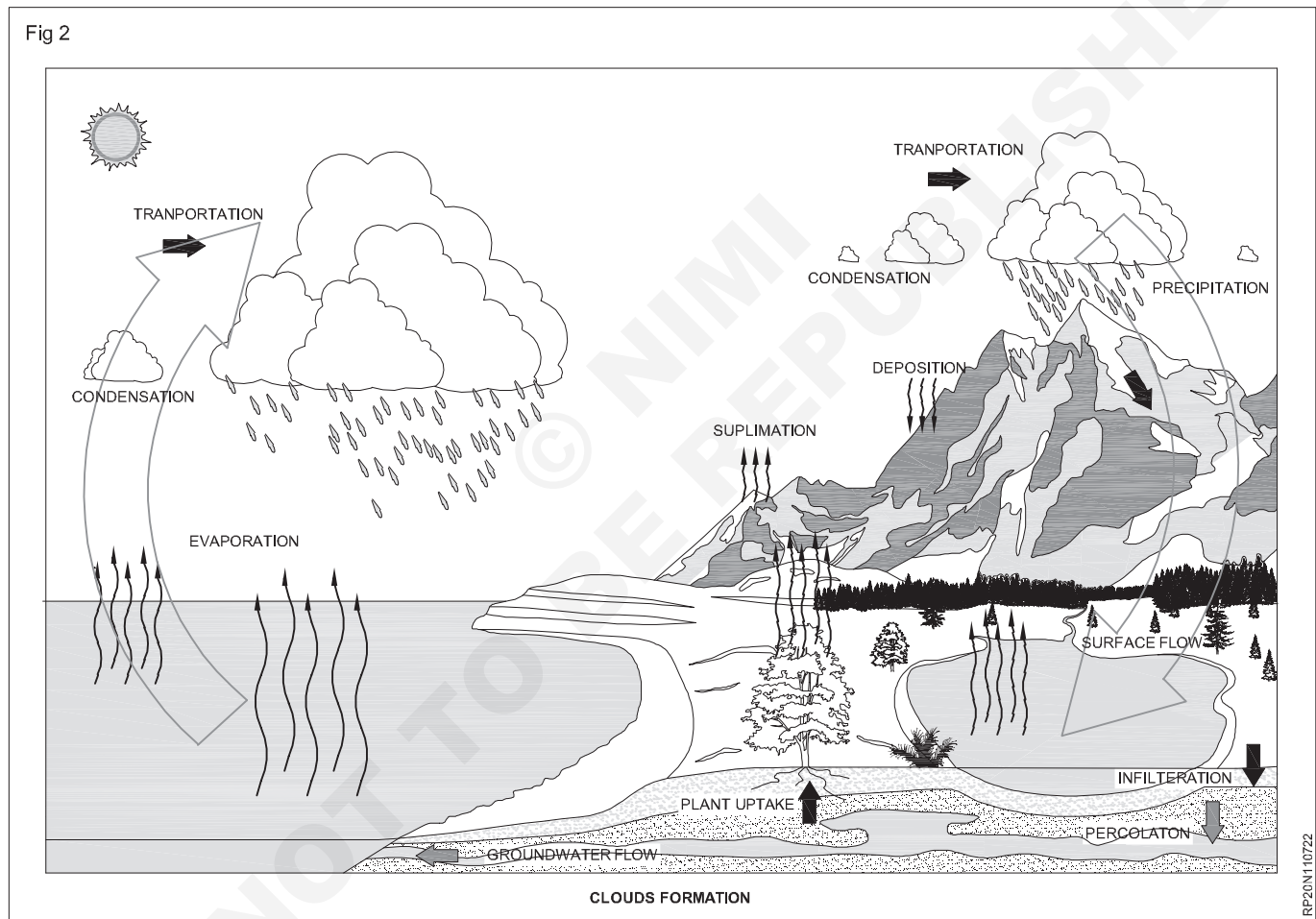

Met Terminal Aviation Routine Weather Report (METAR).

Meteorological Terminal Air Report (METAR)

“METAR” is a format for writing weather report used by “aircraft pilots”, meteorologists and for weather forecasting. It observes weather data at an airport at a specific time.

METAR Coding Name

METAR code at all times in this order:

The description of above terms are as follows.

Place
Date and Time
Wind
Visibility
Phenomena
Clouds
Temperature
Pressure

Place/ Location

In METAR, the first code is the ICAO code indicates the Place/ Location of the airport that issued the report.

Ex. VIDP = New Delhi / Palam, India

Date and Time

A six-number code indicate the day of the month and the time of the observation in hours and minutes UTC.

Ex.301120Z.

- Day = 30
- Time= 11 hours 20 minutes
- Z = Zulu

Wind

This code indicates wind direction in degrees relative to “true north and the average speed of the wind” in knots

Ex. 24018KT

- Wind direction: 240 degrees true

- speed: 19 kts

VRB04KT = variable/4 kts;

00000 = CALM.

Visibility

A four-number code indicate the horizontal visibility in meters. If the visibility more than 10 km is stated by 9999.

Ex. 0600 = 600 meters;

7000 = 7 km

Note:

- 10 km is indicated by 9999.
- 0000 less than 50m

visibility is less than 2000 m, the existing Runway Visual Range (RVR)

Weather

A Weather is indicated by up to 3 groups containing symbols and letters from the following abbreviations:

TABLE 1

- = slight	+ = Heavy	BC = Patches	BL = Blowing
BR = Mist	DR = Low Drifting	DS = Dust Storm	DU = Widespread Dust
DZ = Drizzle	FG = Fog	FC = Funnel Cloud (e.g., Tornado)	FU = Smoke
FZ = Freezing	GR = Hail	GS = Small Hail	HZ = Haze
IC = Ice Crystals	MI = Shallow	PL = Ice Pellets	PO = Dust Devils
RA = Rain	SA = Sand	SG = Snow Grains	SH = Shower
SN = Snow	SQ = Squall	SS = Sandstorm	TS = Thunderstorm
VA = Volcanic Ash	VC = In the vicinity (nearby)	UP = Unidentified Precipitation	RE = Recent

Ex. - IC = Slight Ice Crystals

+ SS = Heavy Sandstorm

Clouds

This code indicates the sky Covered by cloud in oktas and indicating the height is shown in hundreds of feet (ft) of the cloud ceiling. Visibility is at 10 km or greater than abbreviation CAVOK (Ceiling and Visibility OK) and if there are no clouds the abbreviation NSC (No Significant Cloud) is used.

TABLE 2

Temperature

FEW	1 to 2 oktas of cloud cover.
SCT (Scattered)	3 to 4 oktas of cloud cover.
BKN (Broken)	5 to 7 oktas of cloud cover.
OVC (Overcast)	8 oktas of cloud cover (completely overcast).

This code is a four-number code indicate temperature indicate the temperature at the airport and the dew point temperature in degrees Celsius.

Ex: 11/08

- 11°C = Temperature
- 8°C = Dew point

Pressure

The four-digit code indicates the pressure in hectopascals (mbar). It consists of a Q and a four-digit number, which represents the current QNH of the airport, that is, the sea level pressure derived from the airport pressure, expressed in hectopascals.

If “NOSIG” is mentioned after METAR, it means that no major changes in weather conditions are expected within two hours after the METAR is issued.

QNH

QNH is detailed to the nearest whole hectopascal (equivalent to a millibar).

Ex: Q1014 = QNH 1014 Hectopascals.

rounded down and preceded by the letter

AUTO

The optional code word AUTO indicates that the report was produced using automatic observation system information.

Drone pilot (Junior) - Identify & select different types of RPA

Different types of RPAS

Objectives: At the end of this lesson you shall be able to

- differences in Different Types of RPAS
- characteristic of naming
- explore the history of the Hawaiian RPAS.
- find out the amount of RPA
- describe the Airframe
- tell faith
- find the basic components
- current/Future Uses of RPAS.

Fig 1

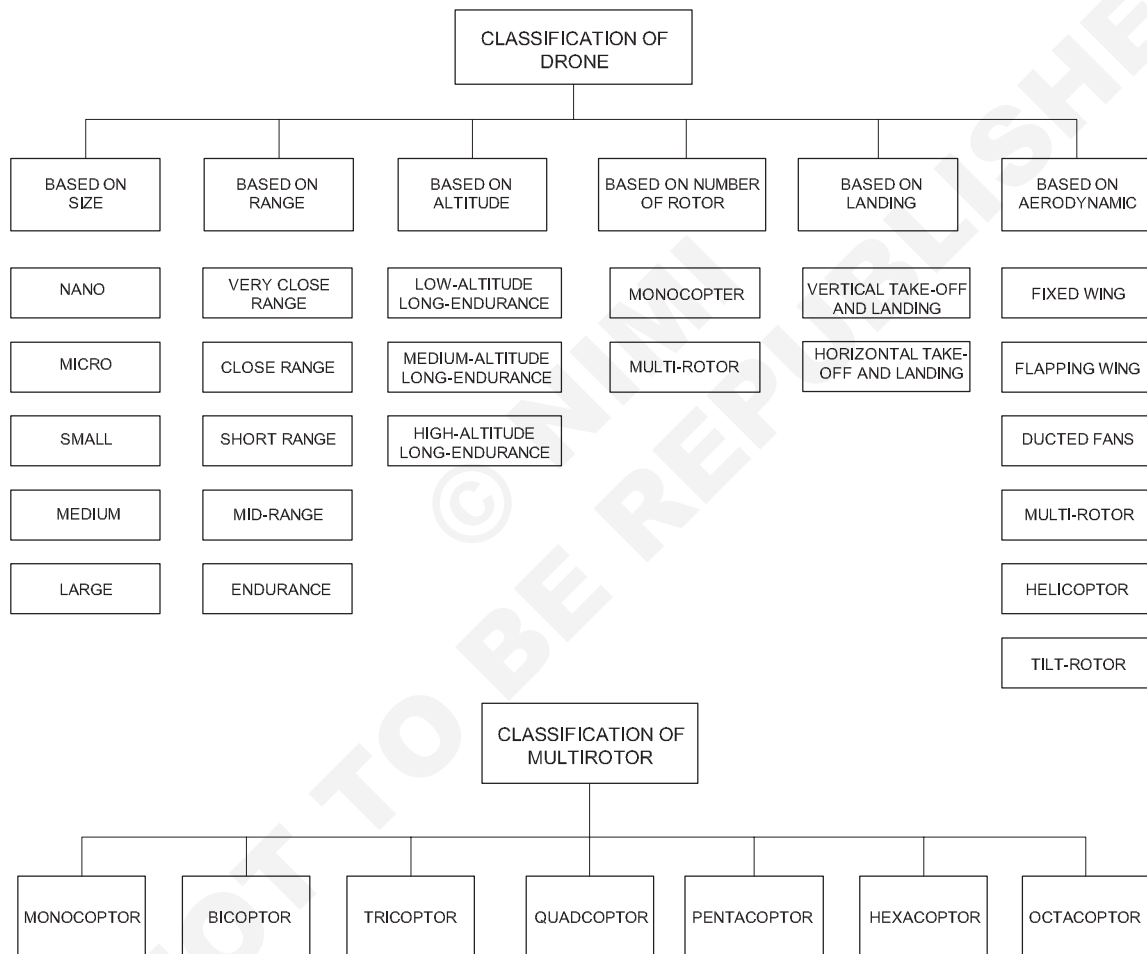

RP20N110741

These categories are specified by the DGCA Civil RPA in conjunction with MTOW (including payload) as shown below:

Nano	Less than or equal to 250grams
Micro	Greater than 250 grams and less than or equal to 2 kg
Small	Greater than 2 kg and less than or equal to 25 kg
Medium	Greater than 25 kg and less than or equal to 150kg
Large	Greater than 150kg

Nomenclatures

AAI	Airports Authority of India	BNF	Bind 'N' Fly
AD	Aerodrome	BVLOS	Beyond Visual Line of Sight
ADC	Air Defence Clearance	CAR	Civil Aviation Requirements
ADS-B	Automatic Dependent Surveillance - Broadcast	CASO	Civil Aviation Safety Officer
AERA	Airports Economic Regulatory Authority	CB	Cumulonimbus
AFRRO	Assistant Foreign Regional Registration Offices	CBEC	Central Board of Excise and Customs
AFS	Aeronautical Fixed Services	CF	Carbon Fiber.
AGA	Aerodrome and Ground Aids	CoG	Centre of Gravity
AGL	Above Ground Level	CISF	Central Industrial Security Force
AHRS	Attitude and Heading Reference System	C-MATZ	(Combined) Military Air Traffic Zone
AIAA	Area of Intense Aerial Activity	CNS	Communication Navigation Surveillance
AIC	Aeronautical Information Circular	CofA	Certificate of Airworthiness
AIP	Aeronautical Information Publication	COSCA	Commissioner of Security
AIS	Aeronautical Information Service	CPWD	Central Public Works Department
AIU	Air Intelligence Unit	CTA	Control Area
AMO	Aeronautical meteorological offices	CTR	Control Zone
AMS	Aeronautical Meteorological Stations	D&A	Detect and Avoid.
AMSL	Above Mean Sea Level	DADF	Department of Animal Husbandry, Dairying and Fisheries
AOA	Angle of attack	DDO	District Development Officer
APHO	Airport Health Organization	DGCA	Directorate General of Civil Aviation
APIS	Advanced Passenger Information System	DGFT	Directorate General of Foreign Trade
ARC	Aviation Research Centre	DGHS	Directorate General Health Services
ARF	Almost ready to fly.	DGPS	Differential Global Positioning System.
ARP	Aerodrome Reference Point (published in AIP)	DIPP	Department of Industrial Policy & Promotion
ASC	Airport Security Committee	DME	Distance Measuring Equipment
ASDA	Accelerate-Stop Distance Available	DPR	Detailed Project Report
ASG	Assistant Secretary General	DSM	Digital Spectrum Modulation
ASP	Airport Security Program	DVOR	Doppler VHF Omnidirectional Radio Range
ASSN	Application Specific Sensor Node.	ECA	Emergency Controlling Authority.
ATC	Air Traffic Control	EDS	Explosives Detection Systems
ATM	Air Traffic Management	EEPROM	Electronically Erasable Programmable Read Only Memory
ATR	Avions de Transport Regional	ELEV	Elevator
ATS	Air Traffic Service	EMI	Electromagnetic Interference.
ATZ	Aerodrome Traffic Zone	ENR	En-route.
AVSEC	Aviation Security	ETA	Equipment Type Approval
AWIS	Aviation Weather Information Service	ETD	Explosives Trace Detection
BCAS	Bureau of Civil Aviation Security	EVD	Explosives Vapour Detection
BEC	Battery Elimination Circuit.	EVLOS	Extended visual line of sight.
		FDI	Foreign Direct Investment
		FHSS	Frequency Hopping Spread Spectrum
		FIR	Flight Information Region

FL	Flight level	MCA	Model Concession Agreement
FMV	Fair Market Value	MEF	Maximum elevation figure.
FOV	Field of View	MEMS	Microelectromechanical systems.
FPV	First Person View	MHA	Ministry of Home Affairs
FRRO	Foreign Regional Registration Office	MoCA	Ministry of Civil Aviation
FRTOL	Flight Radio Telephone Operator's License	MoD	Ministry of Defence
FTO	Flying Training Organization	MOHFW	Ministry of Health & Family Welfare
GCS	Ground Control System	MTOW	Maximum Take-off Weight
GDP	Gross Domestic Product	NBFC	Non-Banking Financial Company
GEN	General	NCASP	National Civil Aviation Security Programmer
GIS	Geographic Information System	NCT	National Capital Territory
GNSS	Global Navigation Satellite System	NOC	No Objection Certificate
GOI	Government of India	NOTAM	Notice to Airmen
GPS	Global Positioning System	NPNT	No Permission-No Takeoff
HHMD	Hand-held Metal Detectors	NQE	National Qualified Entity.
HIRTA	High intensity radio transmission area	NTRO	National Technical Research Organization
HL	Home Lock	OAS	Obstacle Avoidance System
IAF	Indian Air Force	OAT	Outside Air Temperature
IAL	Instrument Activity List	OM	Operations Manual
ICAO	International Civil Aviation Organization	OSC	Operational Safety Case
IFL	Interest Free Loan	OSD	On Screen Display.
IFR	Instrument Flight Rules	PDB	Power Distribution Board
IHR	International Health Regulations	PfCO	Permission for Commercial Operation.
IMD	Indian Meteorological Department	PROP	Propeller
IMU	The Inertial Measurement Unit	PPL	Private Pilot License
INS	The Inertial Navigation System.	PPP	Public Private Partnership
IOC	Intelligent Orientation Control	PWD	Public Works Department
IPC	Indian Penal Code	RF-ID	Radio Frequency Identification
IPPC	International Plant Protection Convention	RNFC	Route Navigation Facilities Charges
ISA	International Standard Atmosphere	RPA	Remotely Piloted Aircraft
ISD	International Subscriber Dialling	RPAS	Remotely Piloted Aircraft System(s)
IST	Indian Standard Time	RPM	Revolutions Per Minute.
JCC	Joint Co-ordination Committee	RPS	Remote Pilot Station(s)
JVC	Joint Venture Company	RSSI	Received Signal Strength Indicator.
LAANC system:	Low Altitude Authorization and Notification Capability system.	RTF	Ready to Fly
LAN	Local Area Network	RtH	Return to Home.
LiPO	Lithium Polymer Battery.	SARPs	Standards and Recommended Practices
LOS	Line of Sight.	SIM	Subscriber Identity Module
mAh	milli Amp Hours.	SPV	Special Purpose Vehicle
MAV	Micro Air Vehicle	SRA	Slum Rehabilitation Act
		STD	Subscriber Trunk Dialling
		SUA	Small Unmanned Aircraft

SUSA	Small Unmanned Surveillance Aircraft
TCAC	Tropical Cyclone Advisory Centre
TFR	Temporary Flight Restriction
TLF	Temporary Landing Facility
TLP	Temporary Landing Permit
TMA	Terminal Control Area/terminal manoeuvring area.
TNLC	Terminal Navigation Landing Charges
TRA	Temporary Reserved Areas
TWR	Tower
TWY	Taxiway
TX	Transmitter or transmit
TSA	Temporary Segregated Areas
UA	Unmanned Aircraft
UAOP	Unmanned Aircraft Operator Permit
UAS	Unmanned Aircraft System(s)
UAVS	Unmanned Aircraft Vehicle System
UDF	User Development Fee
UIN	Unique Identification Number
UNCITRAL	United Nations Commission on International Trade Law
UAV acronyms:	
Uninhabited Aircraft Vehicle	
Unmanned Aerial Vehicle	
Unmanned Aerospace Vehicle	
Unmanned Air Vehicle	
Unmanned Airborne Vehicle	
Unmanned Aircraft Vehicle	
Unmanned Autonomous Vehicle	
Upper Atmosphere Vehicle	
UPS	Uninterruptible Power Supply
UTC	Universal Time Coordinated
UTM	Unmanned Traffic Management
VFR	Visual Flight Rules
VHF	Very High Frequency
VLOS	Visual Line-Of-Sight
VMC	Visual Meteorological Conditions
VOR	VHF Omnidirectional Radio Range
VRX	Video Receiver
VTOL	Vertical takeoff and landing
VTX	Video Transmitter
WGS	World Geodetic System

WHO	World Health Organization
WPC	Wireless Planning and Coordination Wing, DoT
WTO	World Trade Organization
Wx	Weather

History of aerial RPAS

History of drone

1849, Air balloons

Austrians used balloons to drop bombs during attack on city of Venice

1918, Kettering Bug

Designed to drop bombs on the targets during WW1. The war ends before the bug was used

1935, queen Bee

Created in UK, this drone was used by military for moving target practice

1937, Curtiss N2C-2

Used by US Navy as radio controlled aircraft

1941, Radio plane by Reginald Denny

During WW II, Reginald Denny from US created first remote controlled aircraft called radioplane.

1964-1969, the Lightning Bug

It was created for surveillance during cold War by US

1973, mastiv UAV & IAA Scout

Israel developed both unpiloted surveillance machine

1982, Battlefield UAVs

A major milestone. Israel changed the way world was seeing Drones. Destroyed many Syrian aircrafts with minimal loss using UAVs

1986, Reconnaissance Drones

A joint venture between US and Israel produced RQ2 pioneer, a medium size reconnaissance drones.

2001, Predator

Designed in US, this drone is used for surveillance

2003- Present commercial Drones

Commercial drones gain popularity in construction, real estate, search and rescue etc

Reputation,

Now, this drone technology has grown exponentially. The future depends on drones. Lots of companies make drones that are easy to fly, bringing people to the market with low-cost beginner-friendly drone technology. Unmanned aircraft are used in the government and the private sector, such as - wildfire fighting, border-surveillance, spraying pesticides on farms.

Nowadays, the trend of drones has become in today's world, but somewhere famous for drone photography

and also for spraying pesticides in agricultural fields, drones are not only for two-application. There are many such applications which are unknown to all till now. They can be solved with the help of a drone.

The technology of our world is increasing day by day, but drone applications have made our busy life easier.

UAV handling for combat surveillance, weather forecasting, insect spraying and more.

Mostly the drone prototypes are used for military, defense organization. Apart from this, there are many other beneficial things. Real in the future. UAV

technology has become commercial in order to pay high employment opportunities for unemployment.

Airframe, configurations, basic components.

Airframe

The airframe is the supportive basic part for all mounted components. The Frame depends on the overall design & configuration part of the drone. This will be the first decision to design a drone.

Example: - the fuselage, undercarriage, empennage and wings, and excludes the propulsion system.

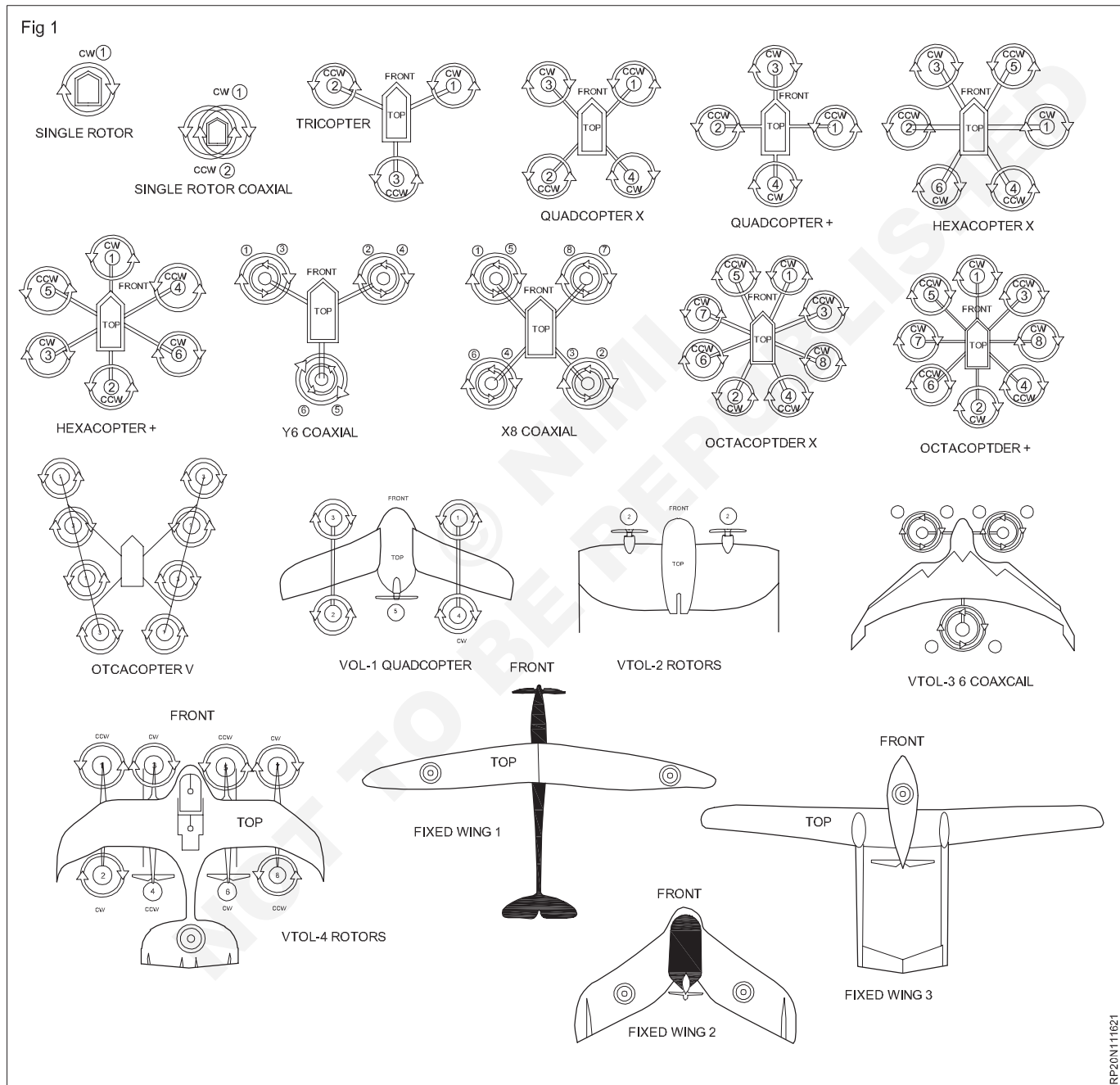

Configuration

The different frame configuration

Basic components of Drone

The main parts are:

- 5 Transmitter box and Receiver
- 6 Battery
- 7 Frame
- 8 Power Distribution Board
- 9 GPS
- 10 Sensors
- 11 Landing gears

Brushless Motors

The motors used in drones are brushless. These motors are familiar for smooth operation by producing the large amount of torque of a Synchronous Motor. Permanent magnets rotate around a fixed armature position.

Propellers

The propellers of the drone help to lift it. Here the rotational motion changed to another form called the anti-thrust force to keep it upwards against the force of gravity. Propellers works on Two Principles.

- 1 Bernoulli's principle
- 2 Newton's 3rd law of motion

ESC'S

The electronic speed controller (controlling electronic device) is used to maintain the speed control of the electric motor & it executes the dynamic break based on the RC models; they are powered electrically. In the case of brushless motors, they generated a low voltage source of 3-phase electrical power energy to drive the motor. The ESC throttle is a separate control unit for the receiving channel.

Flight controller

The flight controller is used to direct the way for hovering. It looks like a small electronic circuit board. Mostly the FCB should have multiple features for flight control.

The command of the pilot is multiple features for flight controlling installed in FC. it directs the motors accordingly. "FC is the brain of drone".

Transmitter Box and Receiver

The transmitter is an electronic device that generates radio frequency by alternating the current. The antenna is elevated by alternating current. The transmitter antenna emits the radio waves to receiver. At where it is transferred to a useful information. The channels differ for different control modes it depends on the type of transmitter setting if we use a four-channel radio transmitter, it can perform to control four- modes instead of controlling more etc.

Receiver

An electronic device, which detects the radio waves & makes them into useful information in a reliable form.

Minimum it requires 4 flight control channel units. Both TX & Rx be on the same channel for better flight communication.

Fig 2



Fig 3

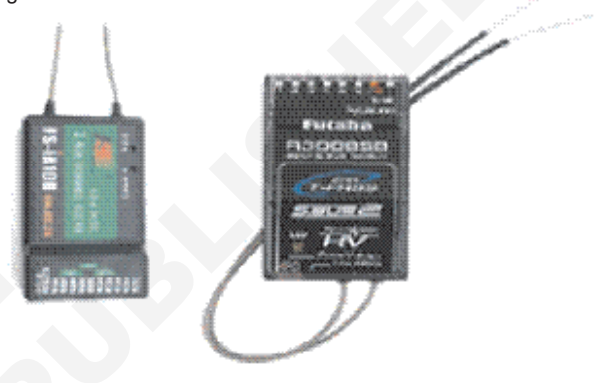

Battery

Lithium polymer batteries are used in custom drones. These are highly weighted. The energy which can be stored at a once, that can be calculated in terms of "mAH". the flight time doesn't depend on the size of the battery. But it depends on the amount of energy stored in battery. After certain flight modulation, the agility of the drone decreased.

Frame

The frame is the supportive basic part for all mounted components. Frame depends on the overall design & configuration part of the drone.

Power Distribution Board

PDB distributes the power for all components of the multirotor. The components are connected on the board with wires and are soldered perfectly. Board confines the circuitry portion for proper arrangement of wire segments.

GPS Module

GPS module helps the drone to navigate longer distances & records the complete info of particular locations on land. GPS navigations track the distance of flight areas. GPS helps the drone to return back home safely.

Sensor

A sensor is a device, which works together with electronic boards. The word "sensor" defines to detect

the physical change that happens in the environment & the output is informed to other connecting electronic gadgets to take quick actions.

Landing Gear

Design is mostly based upon a helicopter landing gear module. The landing place will be widely opened & clearer, which makes the drone perform a safe landing.

Balanced Battery Charger

A smart charger uses smart technologies for charging and balance several cells which are located inside the battery.

Current/ future uses of RPAS.

Military drones:

Military drones are used over a decade of time. UAV used for surveillance, monitoring, commanding target on enemies. However, for this technology Armed forces showing much more interest and they are investing develop the UA. This is building a greater opportunity for drone manufacturing.

Agriculture

Agriculture is an endless process which is made by farmers. The cost expenses for raising up a crop is expendable. This issue will be a burden to spend more money to Agri-Field. To avoid such difficulties, drone providing so many solutions. We all risen-up by learning that (honey-bees) are used for pollinating flower drones also been used to pollinate it will be proved one day, it can compensate the bee declining population. The productivity of field increases. The pest spraying be done with a drone. Drone access the data & provide the information of the field. UAV's have thermal- imaging cameras to detect the diseased parts of the plant for Ex: - raptor maps and Agriculture analytics start up using drone to a better forecast of field. They assisting farmers for potential harvest. Airborne seed dispersal is also possible by drone. Abundant robotics also evolving a solution for autonomously picking.



Agriculture Drone useful:

- 1 Soil Analysis:
- 2 Spraying and sowing:

- 3 Plant Count:
- 4 Health Analysis (Fruits, leaves and flowers)
- 5 Data – Analyzation
- 6 High- efficient work
- 7 Eco- friendly
- 8 Irrigation
- 9 3-D mapping (Land Surveying)

Mining

Drones are used to capture the volumetric data on stockpiles with unique cameras & able to survey Mining operations from the air, which reduces the surveyors on the ground. Mining also being held by autonomous UGV's.

On site drone solution for mining companies to operate work like surveying, security enhancing, measuring materials. The drones are totally autonomous, which can store the data on cloud platform services.

Mapping

So many lands are unavailable to mankind. To take 3D – Mapping. Images, which is easier to find the lands & makes them usable. This can be an organization to make every one available. Finding the location made easier by drone.

Drone Racing & Gaming Sports

Like video gaming, drone gaming be a trend of today. Aerial racing fills us with happiness because no incidents happened in oriented space. Being a hobby to everyone. It creates recreational thoughts in young minds. This aerial flight exercise creates un-condition practices to all. Precautions are mandatory who are participating in drone racing.

Security

Security is most important high alert systems enabling for comprehensive surveillances in industries & residential properties. Even through security is maintain but suspicious activities held at some place. Drone deploys with live streaming then immediately alarm triggered, make the security teams alert and footages can be captured.

Solar Inspection

Now a day's solar project has been developed in many places, it requires solar inspections. To avoid manual work, presently drones are taken part for doing solar inspection and it sends data to Maintenance Department for analyse.

Surveillance & Aerial Monitoring

Drone are used as spy with all certifications. We can avoid risk, issues & security some problems surveillances done by drone are given below.

- 1 Security
- 2 Traffic monitoring
- 3 Board Security

Different types of RPAS

Objectives: At the end of this lesson you shall be able to

- define aerodynamics
- explore the history of the Hawaiian RPAS
- find out the amount of RPA
- define Bernoulli's principle
- describe the four forces of flight
- describe the three routes of flight
- explain how they apply to RPA flying.

Aerodynamics

Aerodynamics is the branch of physics that deals with the motion of air or gaseous fluids and about the forces acting on bodies while passing through fluid or flow of air.

Fluid

A fluid is any substance that flows or deforms under applied shear stress and have the tendency to flow

History of Flight

A Brief History of Flight

His Flying Machine, a design for an ornithopter that was never built but whose concept was later used to create the helicopter.(Fig 1)

- In 1783 - A first manned flight was done by the Montgolfier brother who was created the first hot air balloon.(Fig 2)

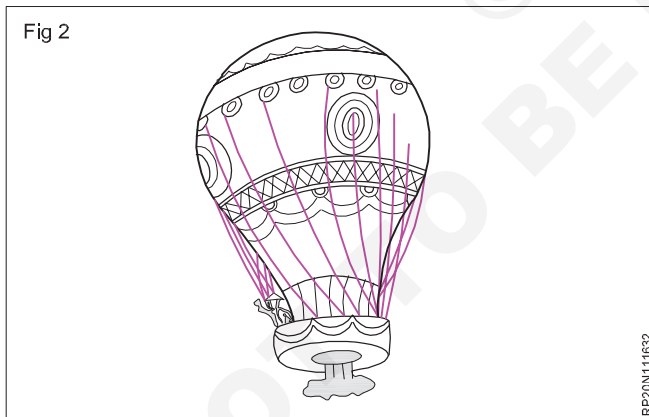
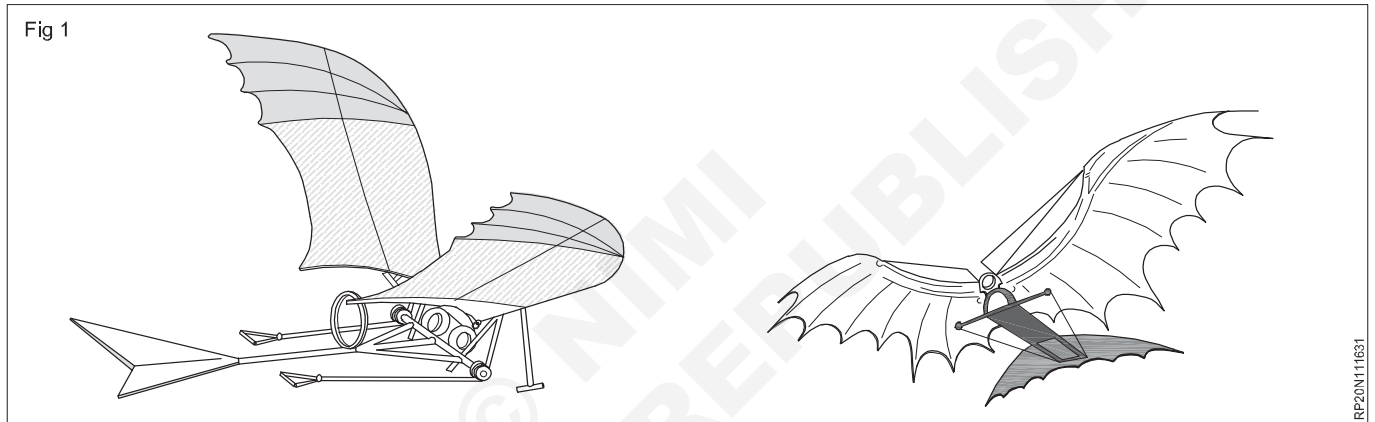

- On December 17, 1903, wright brothers flew the Flyer 120 feet in 12 seconds.(Fig 3)

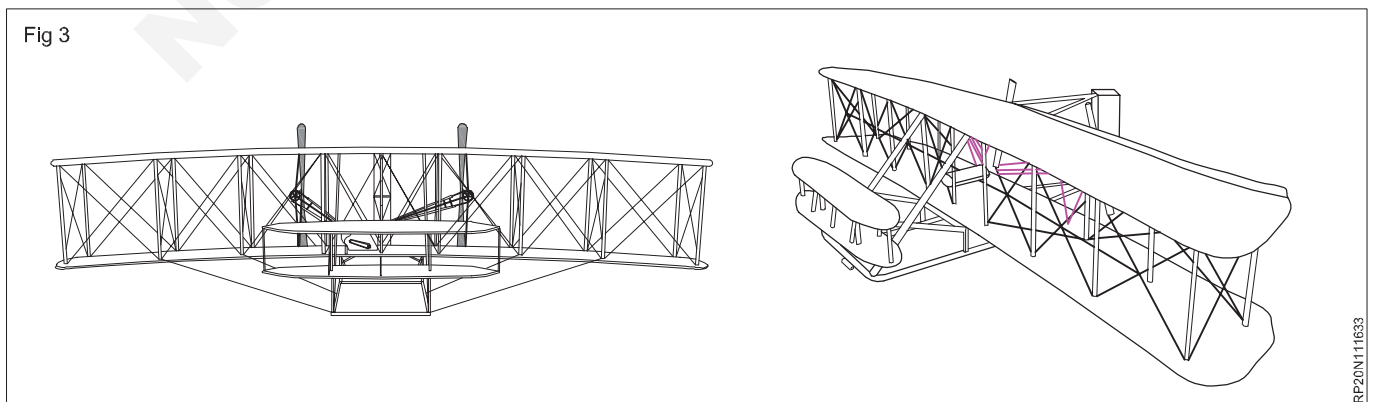

- 1927-Charles A. Lindbergh comes first nonstop trans – Atlantic flight.
- 1939- First Modern Airliner, Boeing 247 files.

Newton’s Laws of Motion (Fig 1)

First Law of Motion: Inertia

A body at “rest or uniform motion” will remain to be at rest or uniform motion until and unless a net external force act on it.

Second Law of Motion: Force

The “second law of motion” states that the applied net force is directly proportional to the rate of change of momentum of a body.

$$F = ma$$

Third Law of Motion: Action & Reaction

The “third law of motion” states that for every action it shows an “equal and opposite reaction”.

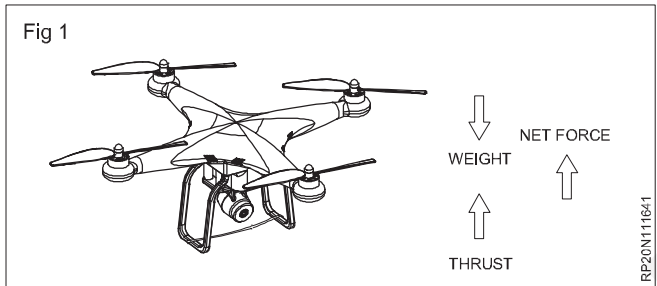

Bernoulli’s Principle (Fig 2)

Bernoulli’s principle plays an important role in understanding air-flow to understand the principle behind drone lift in the air.

Bernoulli’s principle states that a decrease in the static pressure or a decrease in the potential energy of the fluid increases the velocity of the fluid.

Example: The velocity over the upper surface of the aircraft wing is higher than the pressure and at the bottom surface pressure is higher than the velocity of air.

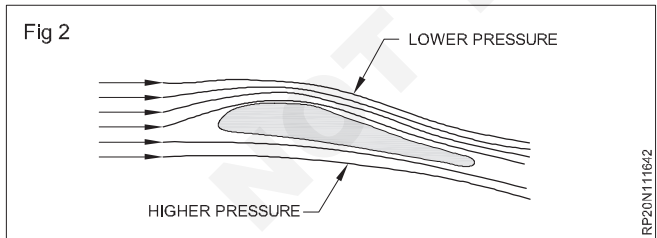

The Equation of Bernoulli’s Principle (Fig 3)

Four forces of Flight (Fig 4)

Four main forces stabilize the flight. For any object to fly, it must balance these four forces (see fig) Forces are:

- 1 Lift
- 2 Drag
- 3 Weight

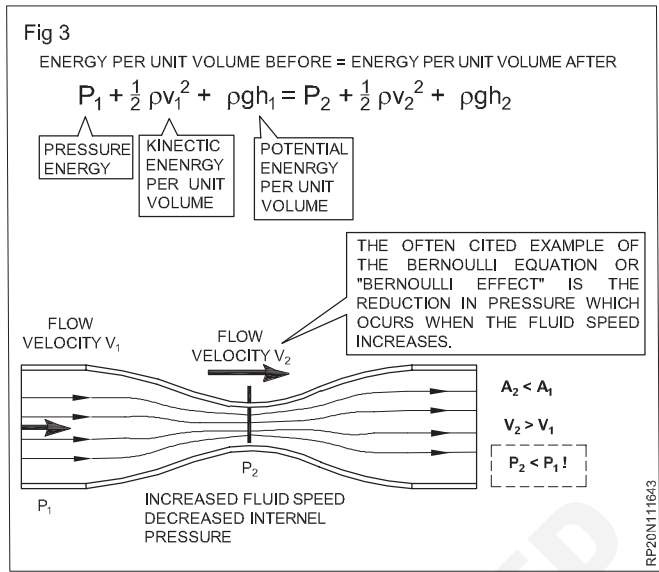

4 Thrust.

The lifting force is used to lift upwards, drag pushes backward, thrust forwards, and weight pushes downwards.

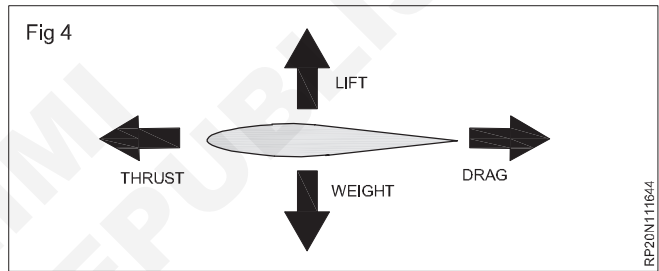

Three Axes of Flight

To stabilize the drone, the rotation of its three axes has to be balanced. Three axes of flight are an imaginary line: “lateral axis, longitudinal axis and vertical axis” (see fig.) on which it can moves Left and Right, Up and Down, Forwards and Backwards.

The Lateral Axis (Pitch)

The lateral axis lies from “wing tip to wing tip”. The drone pitches around this imaginary line (axis).

The Longitudinal Axis (Roll)

The longitudinal axis lies from the “nose of the aircraft” to the tail. This is the imaginary line (axis) around which the drone rolls.

The Vertical Axis (Yaw)

The vertical axis is slightly dissimilar to the other axis, running vertically through the center of the drone.

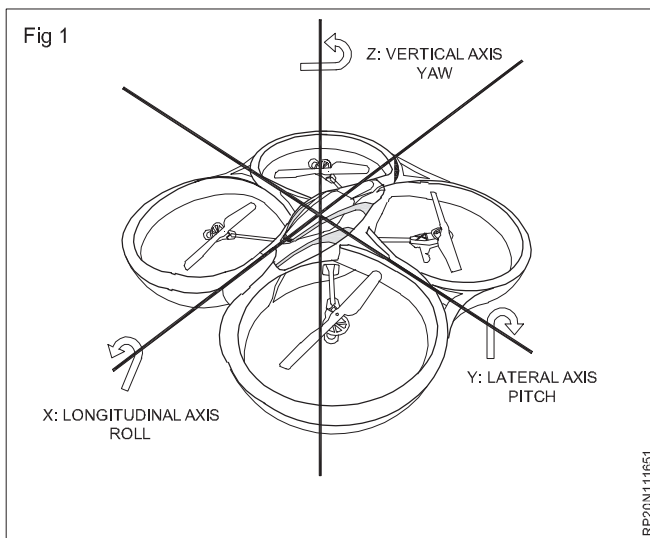

The air velocity decreases and pressure increase at the bottom side of Drone propeller/aircraft wing.

Newton's Laws of Motion

Newton's First Law: Inertia

The motion of an drone when a drone pilot changes the throttle setting of a motor.

Newton's Second Law: Force

An drone motion resulting from aerodynamic forces, aircraft weight, and thrust.

Apply Four Forces of Flight on drone.

Weight

- Due to the mass of the drone, the body mass force always acts in the direction of gravity
- Higher the weight of the drone, more power is required to lift and move the drone.

Weight of drone = mass of drone × acceleration due to gravity

Drag

- The force acting on the drone in the opposite direction of motion due to air resistance is called drag
- This may be because of pressure difference and viscosity of air
- To reduce the drag, the aerodynamic shape of the drone is selected

Thrust

- The force acting on the drone in the direction of motion is called thrust. However, for drone dynamics, it is normal to the rotor plane.

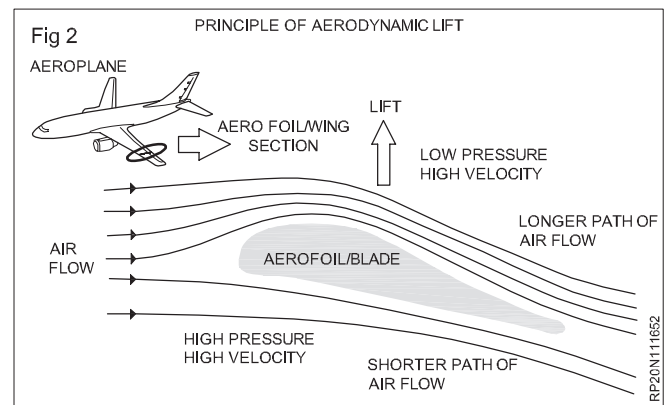

Newton's Third Law: Action & Reaction

The motion of lift from an airfoil, the air is deflected downward

by the airfoil's action, and in reaction, the wing/propeller is pushed upward.

- During hovering, the thrust is purely vertical. If thrust is inclined then the drone will tilt forward or backward.
- This force is essential to move the drone in the desired direction at equal speed to get desired motion, two propellers have been given high speed.

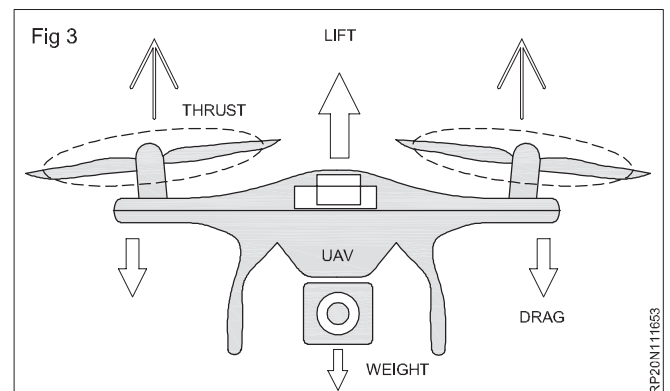

History of helicopter design

Objectives: At the end of this lesson you shall be able to

- describe the history of helicopter design.
- explain electronic rotor design
- attain various faiths
- define size in airspace
- build Materials.

History of helicopter design

S.No.	Year	
1	1100	Chinese flying top
2	1483	Leonardo da Vinci's helical airscrew
3	1784	Launoy and Bienvenu's feather model
4	1843	Sir George Cayley's steam- powered model
5	1907	Paul Cornu's first man-carrying helicopter
6	1916	Istvan Petroczy and Theodore von Karman's tethered helicopter
7	1923	Juan de la Cierva's autogiro
8	1936	Focke Achgelis Fa61, the first successful helicopter
9	1939	Sikorsky VS-300 the first practical helicopter in the U.S

Pre-rotor design. (Early multi rotor design)

Preliminary Black Rotor Design

- The size of the phone was large
- The number of motors was large with the heavy weight
- The drone was selected based on its use
- Oversized propellers unbalanced the drone
- The size of the arms was too big
- Requires higher voltage consumption
- It was operated by a radio-controlled system
- Its efficiency, performance was low
- The materials used in the drone were different
- In the old days power distribution boards were not used.

Various Configurations

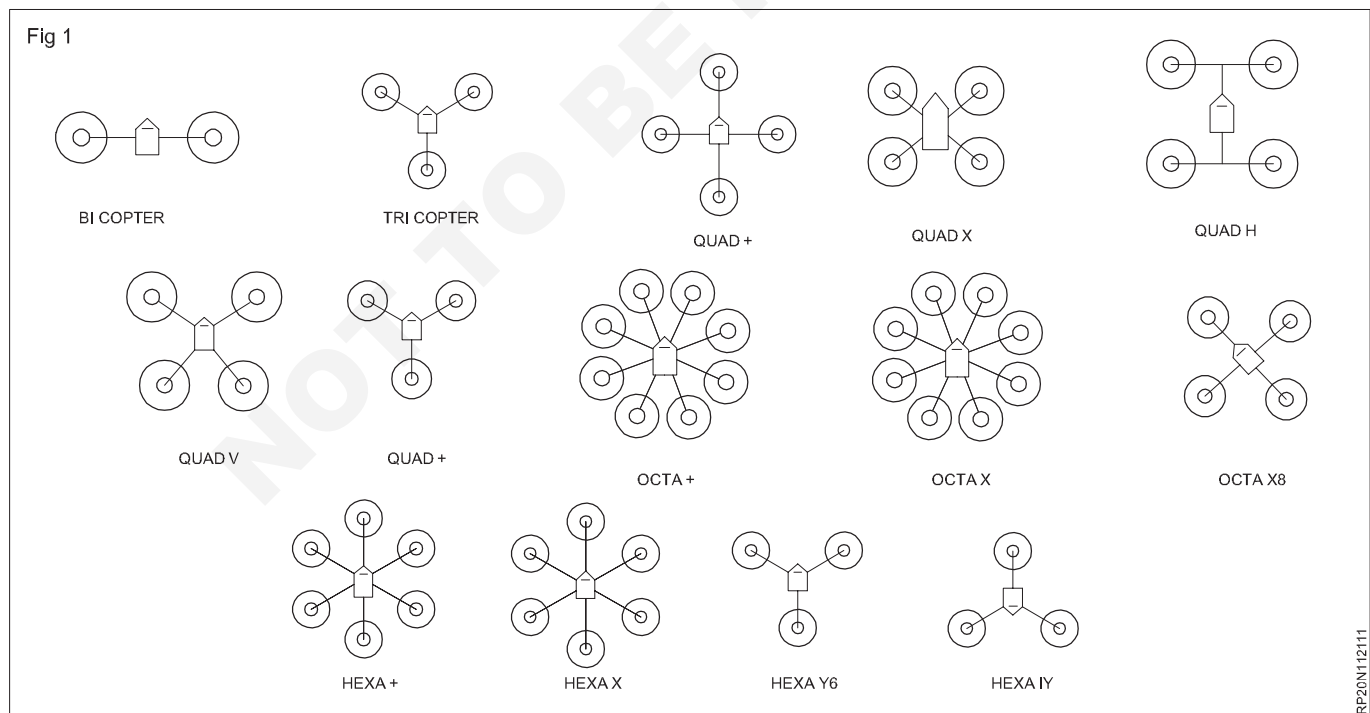

Airframe sizes

- 1 The frame is the supportive basic part for all mounted components.
- 2 Frame depends on the overall design & configuration part of the drone.
- 3 For airframe the main dimension is diagonal distance between two motors.

Trainee should measure the diagonal distance between two motors

Construction Material

- 1 Aluminum
- 2 Plastic
- 3 Wood
- 4 Carbon Fiber.

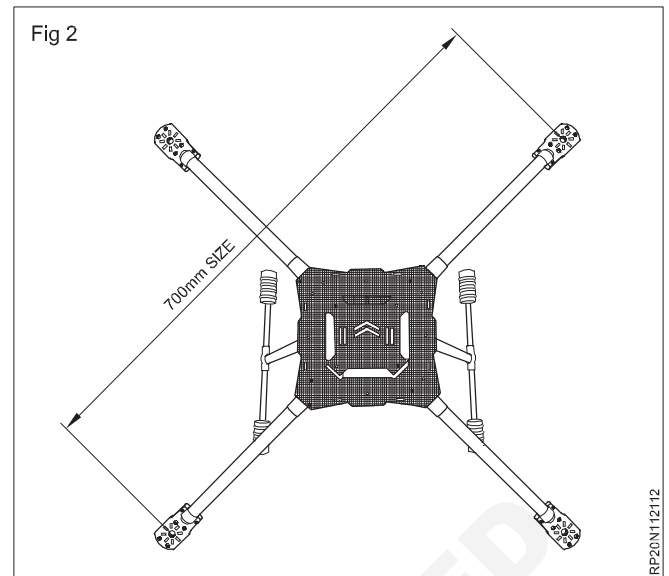

History of propeller design.

Objectives: At the end of this lesson you shall be able to

- describe the history of propeller design.
- define fixed-pitch and constant-pitched blades.
- describe airfoil design, size, pitch, and breadth-count, including balancing devices and construction materials

History of propeller design.

S.No.	Year	
1	400 BC	Archytas, disciple of Pythagoras, puts an inclined plane on a cylinder.
2	220 BC	Archimedes uses screws to lift water.
3	1680	Robert Hooke notes that vanes of a windmill could be used to move water.
4	1752	Bernoulli suggests propelling boats using «vanes set at an angle of 60° to both the arbor and the keel».
5	1770	James Watt proposes a screw propeller, though opposed to use his steam engines on board ships.
6	1776	David Bushnell uses a propeller to drive his submarine Turtle. In contrast to the illustration showing a screw, the propeller was made of single blades.
7	1798	Robert Fulton experiments with a four bladed propeller on a ship.
8	1800	Edward Shorter patents the «perpetual sculling machine». Two years later, HMS Dragon, powered by 8 men at a capstan, achieves 1.5 knots.
9	1829	The Morgan wheel is patented, using Hooke's windmill idea, with feathering vanes.

10	1815	Richard Trevithick designs a propeller with blades placed obliquely on a cylinder, powered by a steam engine.
11	1843	Sir George Cayley designs an ingenious convertiplan, equipped with four rotors and twin propellers.
12	1865	Rankine develops his momentum theory.
13	1878	William Froude develops the blade element theory.
14	1900-1905	The Wright brothers design and test propellers systematically and succeed in 1903, performing their famous first powered flights.
15	1907	Lancaster publishes his «Aerodynamics», including a theory of optimum propellers.
16	1919	Ludwig Prandtl and Albert Betz calculate optimum propellers, having minimum induced loss.
17	1932	Variable pitch propellers are introduced into air force service.
18	1935	Constant speed propellers become available.
19	1939	The Heinkel He 178 makes the first flight of a turbo jet driven airplane.
20	1945	The first turboprop engines are tested by Rolls-Royce on a Gloster Meteor.

21	1980s	NASA and industry perform tests with high-speed propellers (propfans and unducted fans) for transport aircraft
----	-------	--

Fixed-pitch and constant-speed blades

Variable Pitch

A controllable pitch propeller is a propeller that allows the pilot to adjust the pitch during flight. Therefore, the blade angle can be set to optimum values for flight phases such as takeoff, climb and cruise. Some installations are capable of sailing propellers. With a variable pitch propeller, the pilot controls the pitch with his control of the propeller. However, propeller speed varies as a function of engine speed or airspeed, just like a fixed pitch propeller. A more sophisticated variant of the variable pitch propeller is the constant speed propeller, which maintains the same speed during flight regardless of throttle movement or airspeed.

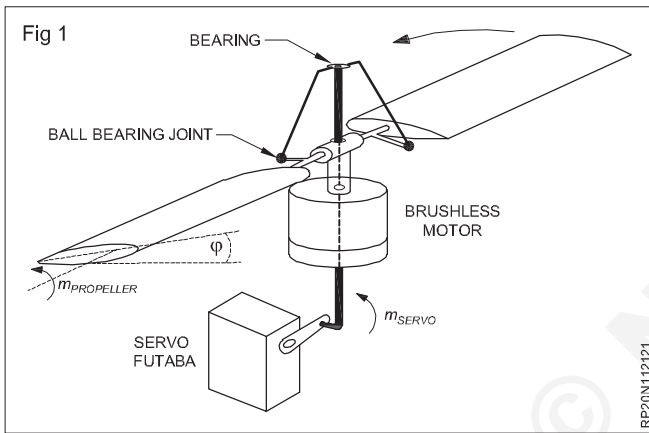

Fixed Pitch

A fixed pitch propeller is the simplest of the propeller designs and is associated with many light, piston engine aircraft. The angle of attack of a fixed pitch propeller is set at installation and cannot be changed during aircraft operation.

(Airfoil design, size, pitch, and blade-count including balancing tips and construction materials)

Airfoil

A structure with curved surface designed to give the most favorable ratio of lift to drag in flight, used as the basic form of the wing, fin, and horizontal stabilizer of most aircraft, an aerofoil.

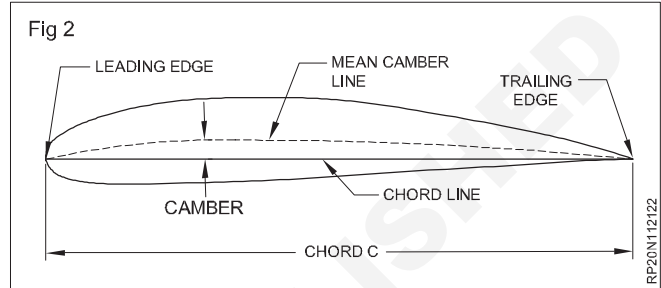

Propellers are described in numbers: the first number is the diameter, and the second number is the pitch. So, a 10 x 4.5 propeller has a diameter of 10 inches, and a pitch of 4.5 inches.

What is pitch in a propeller ?

Propeller pitch is the distance the prop would move forward in one rotation

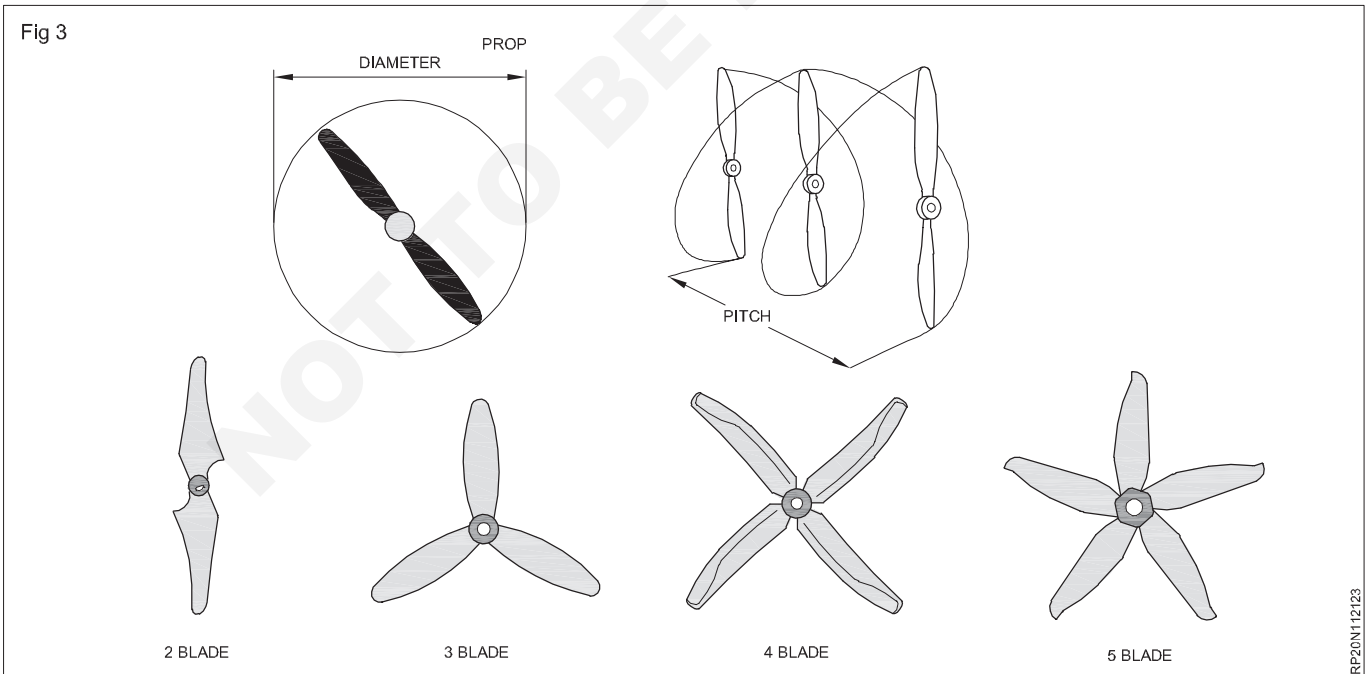

Blade-Count

Propeller balancing

How to tas the propeller on a quad copter spin, it is important that the propeller is balanced. [Equal mass on

both sides] Should they not, the quadcopter may have a slight spin (or) drift. You need propeller balance when it's flying to balance them.

Propeller Balancing Working

Just put the motion into the rod and watch the moment if one side of the propeller is obviously heavy, use some sand paper to rub some of the mass off the top of the propeller to balance it out.

Construction materials

- 1 Aluminum

- 2 Plastic
- 3 Wood
- 4 Carbon fiber

History of batteries

Objectives: At the end of this lesson you shall be able to

- describe the history of the battery
- describe the various makeups, reactions and chemistry.
- finding Parallel vs Serial Mode.

History of Batteries

- | | |
|------|---|
| 1600 | Gilbert –Establishment of electrochemistry study |
| 1791 | Luigi Galvani- discovery of animal electricity |
| 1800 | Alessandro Volta –invention of the voltaic cell (zinc and copper) |
| 1802 | Cruikshank- first electric battery capable of mass production |
| 1820 | Ampere – electricity through magnetism |
| 1833 | Faraday – Announcement of Faraday's law |
| 1836 | John F Daniell – invention of the Daniell cell |
| 1839 | William Robert Grove – invention of the fuel cell (H ₂ /O ₂) |
| 1859 | Gaston Planté – invention of the lead acid battery |
| 1868 | Georges Leclanché – invention of Leclanché cell (carbon-zinc) |
| 1899 | Waldemar Jungner – invention of the nickel-cadmium battery |
| 1901 | Thomas A Edison- Invention of the nickel – iron battery |
| 1932 | Shlecht & Ackermann – Invention of the sintered pole plate |
| 1947 | Neumann – Successfully sealing the nickel-cadmium battery |
| 1949 | Lew Uir, Eveready Battery – Invention of the alkaline- manganese battery |
| 1970 | Group effect – development of the valve regulated lead acid battery |
| 1990 | Group effort- commercialization of the lithium- metal hybrid battery |
| 1991 | Sony- commercialization of the lithium- ion battery |
| 1996 | Moli Energy – introduction of Li-ion with manganese cathode |
| 2006 | Volvo, A123 system – introduction of |

Li-ion with phosphate cathode.

(Various makeups, reactions and chemistry)

Battery v/s Various Makeup:

- Container
- Cathode
- Separators
- Anode
- Electrodes
- Electrolyte
- Kaler

Chemistry of the generation of voltage by lead-acid batteries

Series Connection

Series connection is that components are connected end-to-end in a line to form a single path through which current can flow.

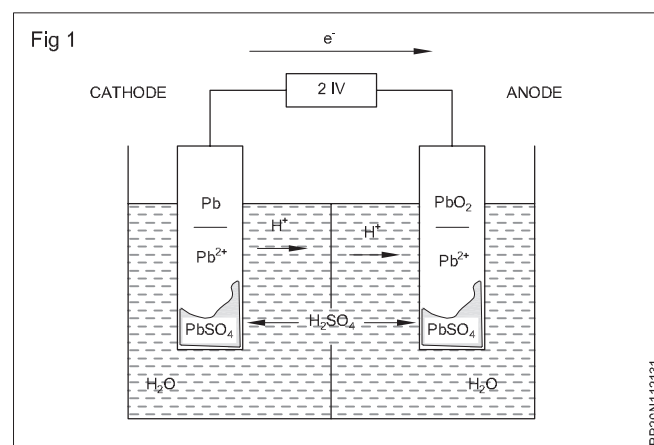

Parallel connection

Parallel connection is that all components are connected across each other's leads.

Series Connection

Series connection is that components are connected end-to-end in a line to form a single path through which current can flow.

Parallel connection

Parallel connection is that all components are connected across each other's leads

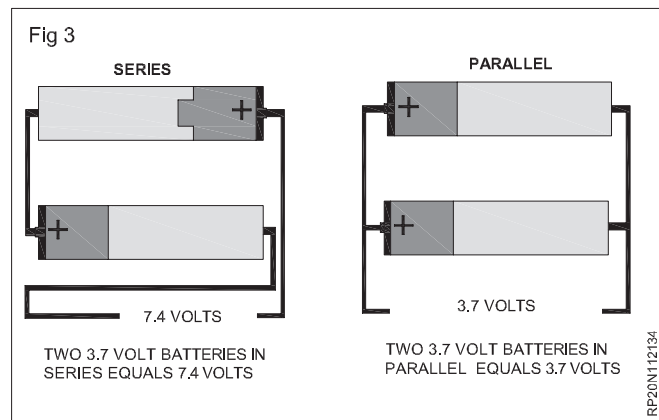
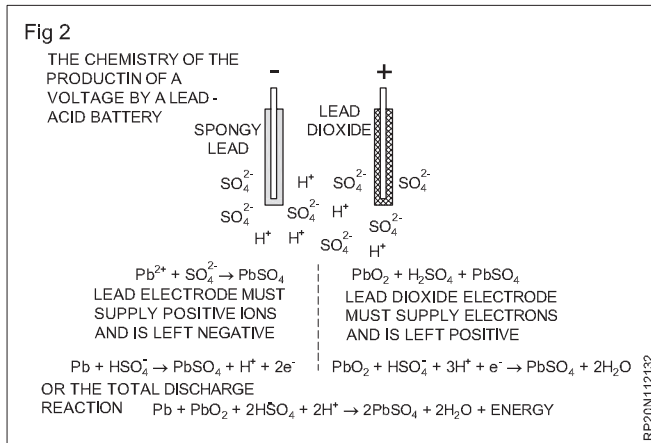

Rechargeable batteries, Li-Po battery characteristics, charging, cell balancing and various connectors

Objectives: At the end of this lesson you shall be able to

- connect battery with charger
- function of battery charger
- identify the battery information and type of battery
- cell balance charging
- identify the Connectors using in battery connection.

Rechargeable Battery List:

- 1 NiCd (Nickel-Cadmium)
- 2 NiMH (Nickel-Metal Hydride)
- 3 Li-ion (Lithium Ion)
- 4 Lipo batteries

Li-Po battery characteristics

- 1 Higher weight-energy rate, volume-energy rate
- 2 High voltage as compare with other batteries. The one cell voltage is 3.7V
- 3 Low self-discharge and long lasting.
- 4 Lipo batteries do not have the so-called memory effect of lithium-cadmium batteries, so there is no need to discharge them before charging them.
- 5 The charge-discharge cycle time is more than 500 times.
- 6 Fast charging.
- 7 Can be used in parallel
- 8 It is environmentally friendly and does not contain heavy metals such as cadmium, lead and mercury.
- 9 Lipo batteries are expensive compared to other batteries.

Check the frame outside the battery. There is no crack or bulge



Visually battery for inspect the outside body for any physical damage or bulging.

Once check manual by the battery manufacture pertaining to charging methods

- 1 Connect battery adaptor with charger and electricity plug
- 2 Connect the battery to the terminal of the charger: red is positive and black is negative. And JST wire of the battery.
- 3 Switch "ON" electricity plug.
- 4 Use START/ENTER, DEC or INC key to set specific details fed into the battery from table 1.
- 5 The left side of the first line indicate the type of

Fig 2

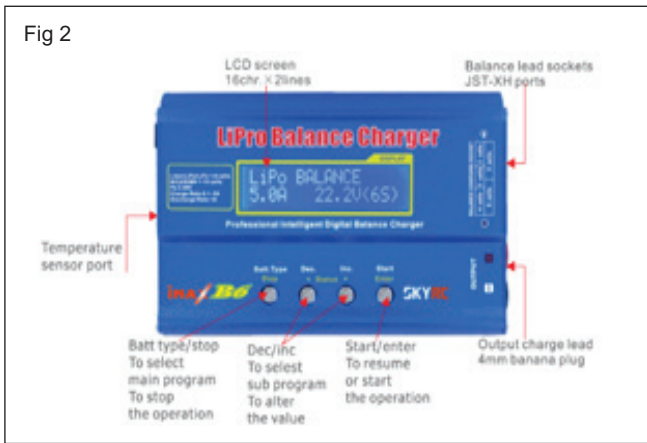

When connecting the battery charger to the battery, you should consult the information regarding the appropriate charging conditions depending on the charger.

- For change the values of parameters, please press START/ENTER key to make it blink and use DEC or INC to change the value. Then press START/ENTER key again to store the value.
- Check on screen, "R" shows the number of cells detected by the charger and "S" is the number of cells set by you at previous screen.
- If details correct press START/ENTER button, if not press BATT TYPE/STOP button to go back to previous screen to check number of cells of the battery pack.

	No.of cells	Rated voltage (V)	Max. charge voltage (V)	Charge current (A)
Lipo	1S	3.70	4.20	5.00
	2S	7.40	8.40	5.00
	3S	11.10	12.60	4.50
	4S	14.80	16.80	3.38
	5S	18.50	21.00	2.70
	6S	22.20	25.20	2.25

battery, left side of the second line indicates current.

- After setting the current and voltage, press START/ENTER key for more than 3 second to start the process.

Fig 3

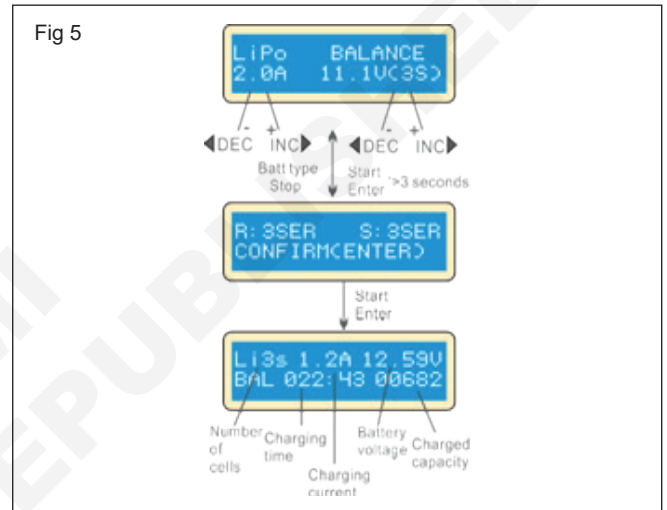
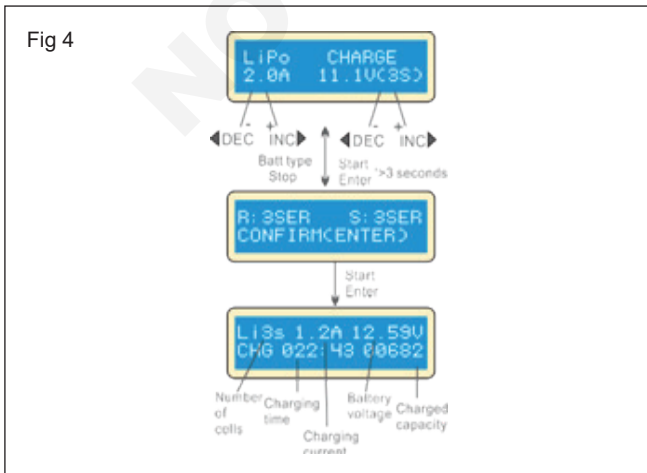

Fig 6



Fig 4



- Switch OFF the battery charger and disconnect the battery when fully charged.

Avoid charging your battery beyond 100%

Batteries balancing charging

- Repeat above steps 1 to 4
- While settings select Balance charging option in charger
- Repeat remaining steps from above

3 XT90 Connector

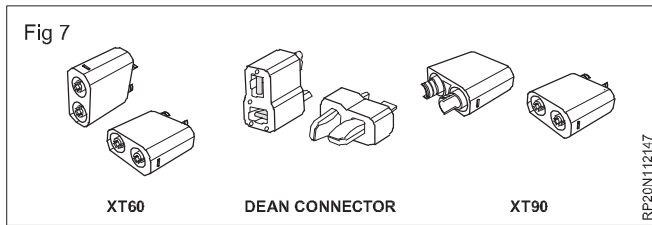

Type of battery Connector

The connector is used to connect your drone to a Battery. A high-amp, more reliable, and better-quality connection is perfect for applications that require a high current draw. There are different types of connectors using for connection.

- 1 Dean Connector
- 2 XT60 Connector

AC/DC motor differences.

Objectives: At the end of this lesson you shall be able to

- difference Between AC/DC Motor
- find out the distance and voltage ratings
- describe the history of electric motors.
- differential Brushed v/s. Brushless motors
- tell us about the Kv rating
- determine motor capacity for RPA sales.

Difference Between AC and DC Motors

AC Motors	DC Motors
AC motors run on AC power.	DC motors run on direct current.
AC motors do not require current conversion.	A DC motor must convert current, such as AC to DC.
AC motors are used where long-term performance is required.	DC motors are used when the speed of the motor needs to be controlled externally.
AC motors can be single-phase or three-phase.	All DC motors are single phase.
In an AC motor, the armature does not rotate while the magnetic field rotates continuously.	In a DC motor, a rotating magnetic field causes the armature to rotate.
DC motors are expensive to repair.	AC motors are inexpensive to repair.
AC motors do not use brushes.	DC motors use brushes.
AC motors have a longer spam life.	DC motors do not last long.
AC motor speed is controlled by simply changing the current frequency.	DC motor speed is controlled by varying the current in the armature windings.
AC motors require an effective starting device, such as a capacitor, to initiate operation.	DC motors do not require external help to start.

What is Voltage and Current rating?

The rating of an electrical appliance indicates the voltage at which the appliance is designed to work and the current consumption at that voltage. These are usually displayed on a rating plate attached to the appliance, e.g., 220 volts, 3 amperes.

History of electric motors.

Inventions began 1740

Scientist continued to develop early electric motors, experimenting with electromagnetic fields and discovering how to convert electrical energy into mechanical energy.

The first electric motor is made 1834

History was made when Thomas davenport of Vermont invented the first official battery-powered electric motor in 1834.

The invention of the DC motor 1886

William sturgeon invented the first DC motor that could provide enough power to drive machinery

Motor is used for commercial purpose late 1880s

Electric motors were not widely used on a commercial level for another 50 years.

The AC induction motor is patented 1888

In 1887, Nikola Telsa invented an AC INDUCCION motor that he successfully patented a year later

The development of three-phase motors 1891

In this year, General Electric started developing three-phase induction motors.

Use of motor today 2000s

In the 21st century AC and DC electric motors are now widely used in industries across the globe and are an integral part of many applications.

Brushed v/s. Brushless motors

Brushed

- 1 It uses brushed to deliver current to the motor windings through mechanical commutation.

- 2 Armature winding is on rotor
- 3 Fixed magnets are placed on either side of the rotating electromagnet
- 4 Current is delivered to the commutator coils by metallic brushes
- 5 Low overall construction cost thanks to simplified wiring
- 6 Inexpensive and reliable but brushes require periodic maintenance
- 7 Low speed range due to limitations by the brushes.

Brushless

- 1 It uses electrical commutation instead of mechanical commutation to deliver current.
- 2 Armature winding is on stator
- 3 Fixed magnets are mounted on the rotor
- 4 Fixed magnets are mounted on the rotor
- 5 It employs control circuitry instead of using brushes
- 6 Less maintenance due to lack of brushes
- 7 Little expensive but efficient and require no maintenance
- 8 High speed range and low noise operation

Calculate motor ratings

Motor Kv Ratings

All brushless motors have the Kv ratings. It indicates the number of “revolutions per minute” (rpm) that a motor turns when 1V (one volt) is applied with no load attached to that motor.

The Kv rating is the ratio of the motor without a load rpm to the peak voltage on the wires connected to the coils.

Inventions began 1740

Scientists continued to develop early electric motors, experimenting with electromagnetic fields and discovering how to convert electrical energy into mechanical energy.

The first electric motor is made 1834

History was made when Thomas Davenport of Vermont invented the first official battery-powered electric motor in 1834.

The invention of the DC motor 1886

William Sturgeon invented the first DC motor that could provide enough power to drive machinery.

Motor is used for commercial purpose late 1880s

Electric motors were not widely used on a commercial level for another 50 years.

The AC induction motor is patented 1888

In 1887, Nikola Tesla invented an AC induction motor that he successfully patented a year later.

The development of three-phase motors 1891

In this year, General Electric started developing three-phase induction motors.

Use of motor today 2000s

In the 21st century AC and DC electric motors are now widely used in industries across the globe and are an integral part of many applications.

Brushed v/s. Brushless motors

Brushed

- 1 It uses brushes to deliver current to the motor windings through mechanical commutation.
- 2 Armature winding is on rotor
- 3 Fixed magnets are placed on either side of the rotating electromagnet
- 4 Current is delivered to the commutator coils by metallic brushes
- 5 Low overall construction cost thanks to simplified wiring
- 6 Inexpensive and reliable but brushes require periodic maintenance
- 7 Low speed range due to limitations by the brushes.

Brushless

- 1 It uses electrical commutation instead of mechanical commutation to deliver current.
- 2 Armature winding is on stator
- 3 Fixed magnets are mounted on the rotor
- 4 Fixed magnets are mounted on the rotor
- 5 It employs control circuitry instead of using brushes
- 6 Less maintenance due to lack of brushes
- 7 Little expensive but efficient and require no maintenance
- 8 High speed range and low noise operation

Calculate motor ratings

Motor Kv Ratings

All brushless motors have the Kv ratings. It indicates the number of “revolutions per minute” (rpm) that a motor turns when 1V (one volt) is applied with no load attached to that motor.

The Kv rating is the ratio of the motor without a load rpm to the peak voltage on the wires connected to the coils.

$$K_v = \frac{\text{RPM}}{\text{Peak Voltage}}$$

Drone thrust to weight ratio

- 1 Determine the optimal thrust of the drone motor, you need to pick one more important parameter: the thrust to weight ratio.

- 2 Find out the total weight of our drone
- 3 Then calculate thrust required for drone with the weight to thrust ratio 1:2.5
- 4 Divide the calculated thrust by the number of motors using to build drone.
- 5 Check the motor rating in Table 1.

TABLE 1

Number of Cells	Thrust	Motor Rating (Kv)
1-2S	250-500 g	2300
2-3S	1.2-1.5 kg	1250
3-4S	2-2.5 kg	830
4-5S	2.5-3.5 kg	730
5-6S	3.5-4.5kg	550
6-8S	4.5-5kg	275
8-10S	5-8kg	190
10-12S	8-10kg	100

After calculate the motor rating get it approved your instructor.

Introduction to the history radio control systems

Objectives: At the end of this lesson you shall be able to

- visit History Radio Control System
- describe the controllers, transmitters and receivers,
- by procuring D.C. Band and programming transmission transmitters.

In 1950 The first remote intended to control a television was developed by Zenith Radio Corporation

In 1955 a wireless remote control, the “Flashmatic” was developed by Eugene Polley

In 1956, Robert Adler developed “Zenith Space Command,” a wireless remote

In 1970, RCA introduced an all-electronic remote control that uses digital signals and metal–oxide–semiconductor field-effect transistor (MOSFET) memory.

The impetus for a more complex type of television remote control came in 1973, with the development of the Ceefax teletext service by the BBC.

In the 1990s, cars were increasingly sold with electronic remote control door locks

By the early 2000s, the number of consumer electronic devices in most homes greatly increased,

Controllers, transmitters and receivers, Frequency bands and programming transmitters.



Band Name	Frequency Range
Very Low frequency	3 to 30 kHz
Low frequency	30 to 300 kHz
Medium frequency	300 to 3000 kHz
High frequency	3 to 30 MHz
very high frequency	30 to 300 MHz
Ultra-high frequency	300 to 3000MHz
Super high frequency	3 to 30 GHz
Extremely high frequency	30 to 300 GHz
Terahertz	300 to 3000GHz

Programming the Transmitter to Channel 1.

Press and hold the white MEM/DEL button in the Control Panel - you'll hear a long beep.

Press and hold the MEM/DEL button while simultaneously pressing the selected button on your transmitter. The longer beep will turn into a faster beep - this means that the channel is now programmed.

Release both buttons and test your transmitter.

The channel chosen will operate as open/stop/close/stop.

Introduction to role of ESCs

Objectives: At the end of this lesson you shall be able to

- explain the role of ESC
- describe how they work
- check PDM, PPM
- get ESC Calculation
- differentiate between Simon's and B.L.Healy's
- obtain firmware vendors
- define BEC, AUTO and UBEC.

ESC stands for Electronic Speed Control, an electronic circuit used to change the speed of an electric motor. These are commonly used in electric radio-controlled models, and the modifications most commonly used for brushless motors essentially provide an electronically generated three-phase low-voltage power supply to the motor. The ESC may be a separate unit that connects to the control channel received from the throttle, or it may be integrated into the receiver itself like most toy quality RC cars.

Features of an ESC

- 1 ESC controls the motor rotation speed of the drone.
- 2 Serves a similar purpose as throttle servos on glow ignition drones
- 3 The edge between the drone's radio receiver and the power plant

- 4 Electronic cruise control consists of 3 sets of cables
- 5 Cable to connect to the main battery of the drone
- 6 The second wire has a typical servo wire that plugs into the throttle channel of the receiver. And finally, one-third of the wires are used to power the motor.
- 7 The main functions of the electronic speed controller include battery less circuit, low voltage cutoff and brake.

How they work

An electronic speed controller controls the speed of a brushless motor by activating the appropriate MOSFETs to generate a rotating magnetic field that rotates the motor. The higher the frequency, or the faster the ESC runs his six intervals, the higher the engine speed.

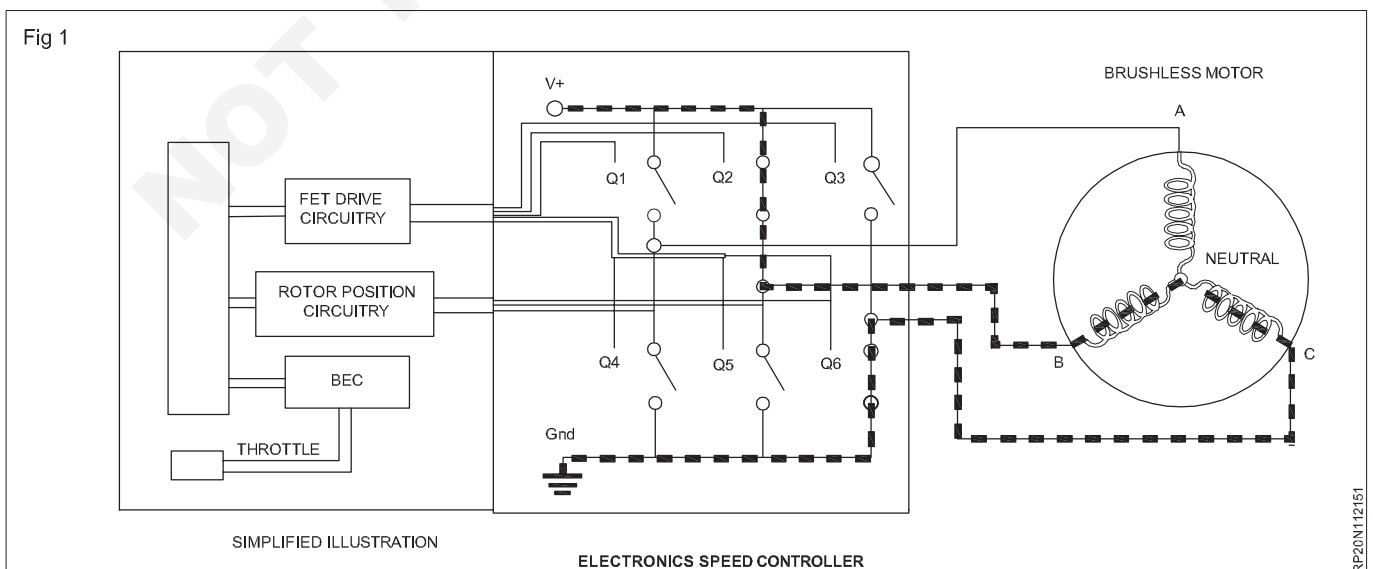

PWM receivers: PWM (Pulse Width Modulation) receivers use one servo wire for each channel. So, for 4 channels, 4 servo wires are used going to the channel's port on the receiver. PWM receivers are comparatively large because of so much wiring.

PPM receivers: PPM (Pulse Position Modulation) sends multiple PWM signals through a single wire in succession. PPM is preferable because in this only a single wire is required and it can carry all the Channel signals required with the maximum of 8 channels and is very useful in small, clean builds.

PPM and PWM signal graph

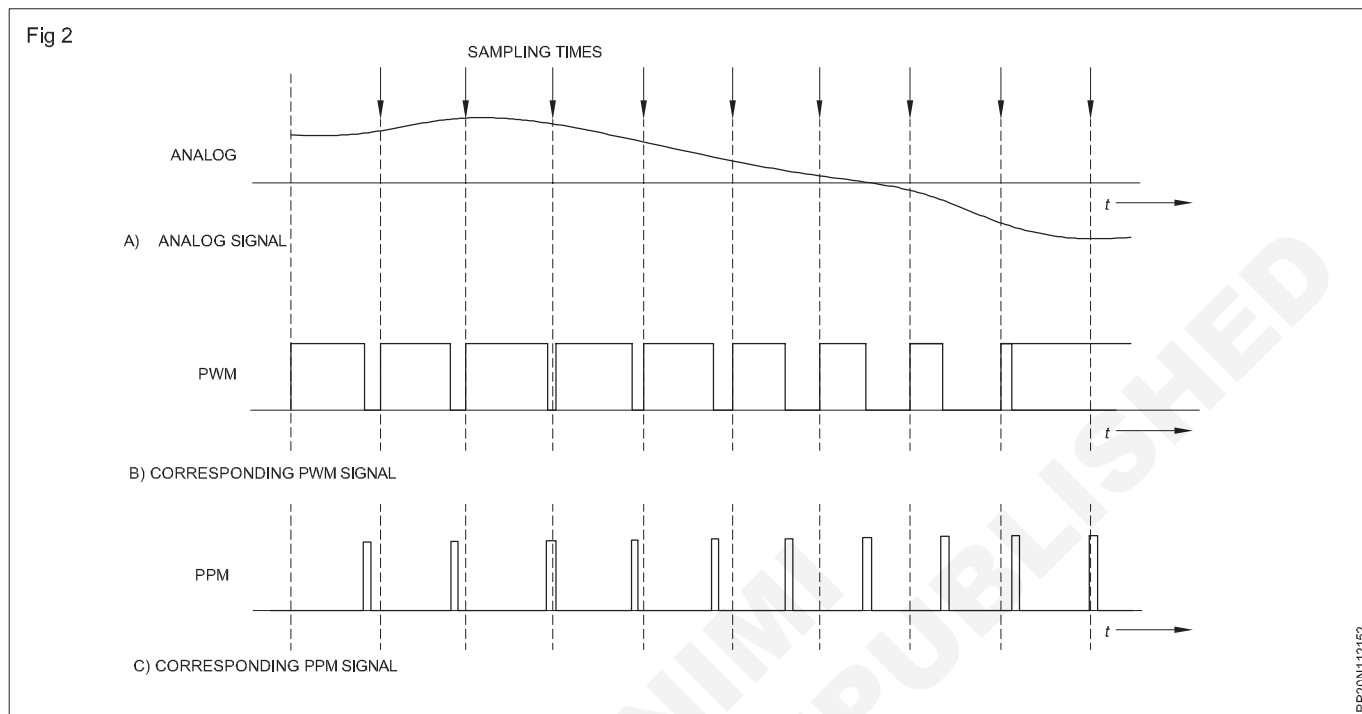

ESC calibration

- 1 Firstly, connect one ESC three-wire cables into the throttle channel (mostly channel 3) of the RC receiver.
- 2 Second trainee turns "ON" the transmitter and set throttle stick to maximum position (at 100%).

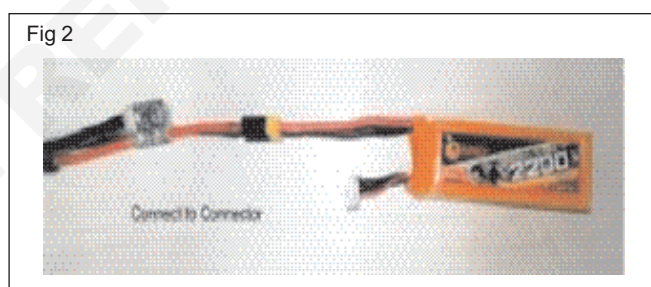

- 5 After the two beeps, pull the transmitter's throttle stick down to its minimum position (at 0%).

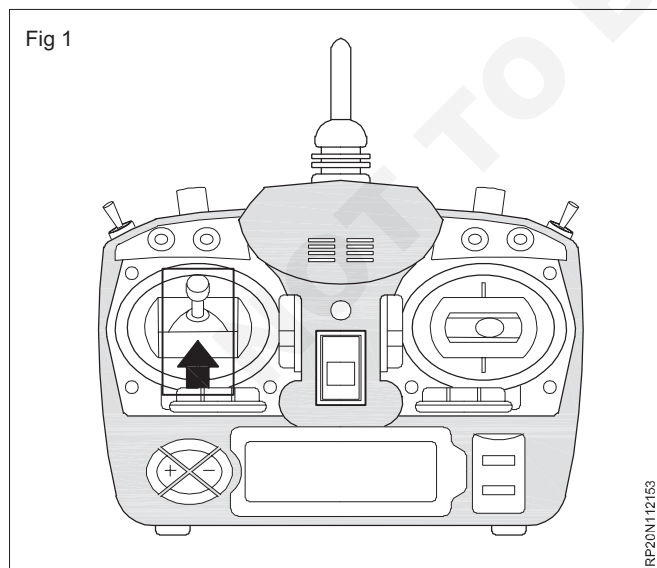

- 3 Third trainee, power to drone by connect the LiPo battery.
- 4 Listen a musical tone than one or two beeps.

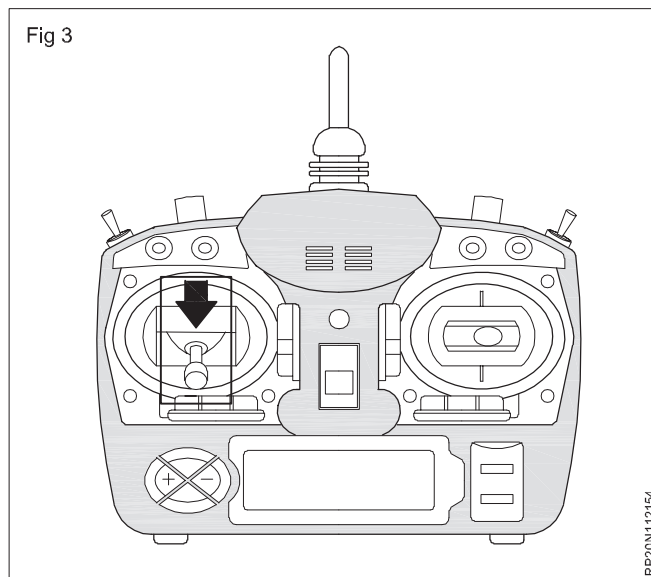

- 6 Then a number of beeps and finally, a single long beep indicating the end points have been set and the ESC is calibrated.
- 7 Disconnect battery.
- 8 Repeat these steps for all other ESCs.
- 9 After calibration, recheck those motors should work in coordination with throttle stick i.e., as soon as the throttle stick is moved from its minimum position, motor should start rotating.
- 10 Make sure that all ESC's are calibrated and are working properly.
- 11 Get it checked by your instructor by Arm your Drone then, put throttle (10%) and check whether all motors are rotating at the same speed and start at the same time.
- 12 Disarm your drone.
- 13 If the motors do not all start at the same time and rotate at the same speed, the ESCs are still not properly calibrated so, repeat above step again.

Simon KVs. BLHeli firmware options and BEC, OPTO, and UBEC

Simon vs BLHELI

Simon firmware has issues when require to use it with low Kv motors, but the latest version states more features.

The BLHELIS firmware allows the user to configure the esc settings through her PC with the BLHELI suite. In general, the way musical tones are composed esc is fine, but for a slightly deeper composition process he might be better off with the BLHelieute due to the BLHeli suite.

BEC ESC

BEC stands for Battery Eliminating Circuit. In practice, this simply means that an ESCS with a BEC can output a constant voltage to power devices on board the flying platform such as receivers, servos and flight controllers.

OPTO ESC

ESCS without BEC is often called OPTO. This is all the same in many multirotor setups like yours the part of the ESC that receives the signal from the flight controller or R/C receiver isolated from the larger voltage circuit driving the motors OPTO ESC means as above, you always need a BEC.

UBEC ESC

UBEC stands for Universal, sometimes Ultimate BEC, and is used when the ESC doesn't have built-in BEC and only needs a power system. They are generally more diverse, more reliable, and more up-to-date than BEC. Like the ESC, the UBEC is directly connected to the multicopter's main battery.

Introduction to role of flight controllers

Objectives: At the end of this lesson you shall be able to

- **find out the role of flight controllers**
 - **describe how they work.**
-

Flight controller

- A circuit board with electronic chips.
- The flight controller is the brain of a drone.
- Intelligent electronics and software that monitor and control everything the drone do.
- Flight controller is connected to a set of sensors.

How they work

Flight controller

- The flight controller uses the data collected from the sensors to calculate the required speed for each of the four motors.
- The flight controller sends this desired speed to the electronic speed controller (ESC).
- The ESC translates this desired speed into a signal that the motor can understand.

Introduction to sensors

Objectives: At the end of this lesson you shall be able to

- **define sensor.**

A sensor is a device, which works together with electronic boards. The word “sensor” defines to detect the physical change that happens in the environment & the output is informed to other connecting electronic gadgets to take quick actions.(Fig 1)

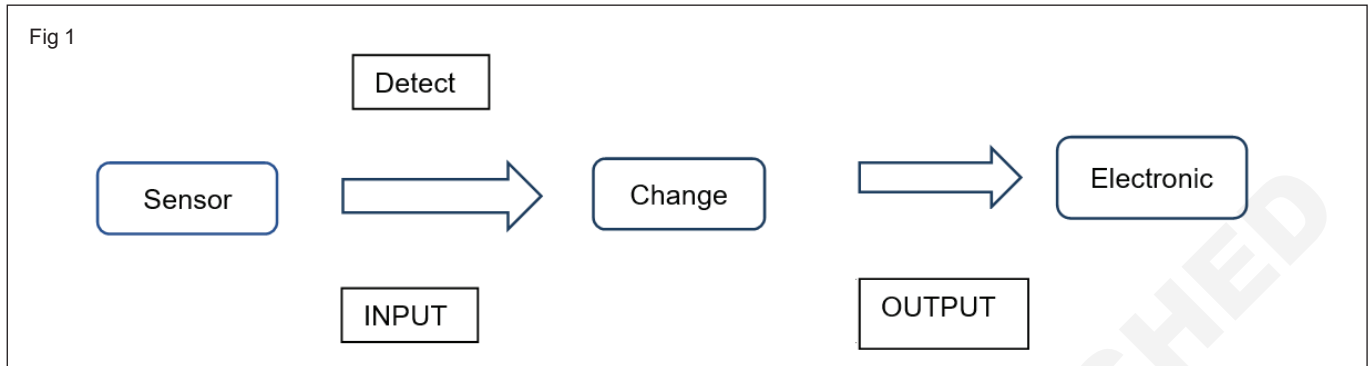

Sense-and-avoid technology (Fig 2)

Several important parameters can change during evasive maneuvers, including the UAV's position, speed, size, and orientation. This cycle is continually repeated to capture the next mapping environment, but at the same time the UAV must look ahead to forcefully pursue operational goals. The sensing function's ability is to predict the speed and trajectory of a moving intruder, as well as detect the presence and location of an intruder.

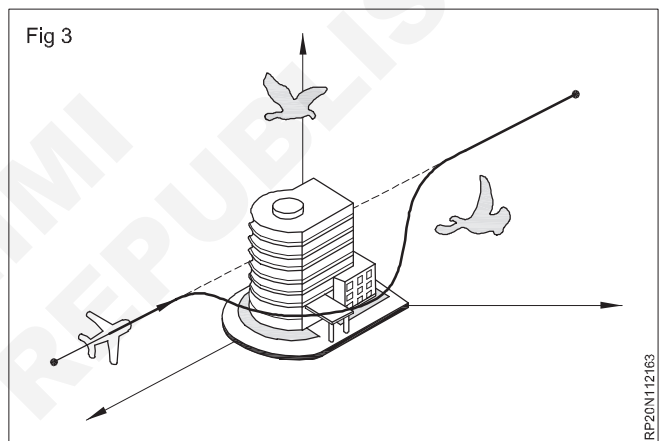
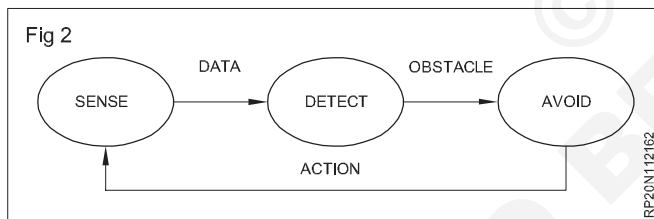

GPS

Objectives: At the end of this lesson you shall be able to

- **discuss about GPS.**

GPS Module : GPS module helps drone to navigate longer distance & records the complete info of particular locations on land. GPS navigations tracks the distance of flight areas. GPS helps drone to return back home safely.

Modern drones have GPS module if its losses connection with the controller. It helps the drone to make it safe. GPS module is responsible for drone latitudinal, longitudinal & elevation provision points.

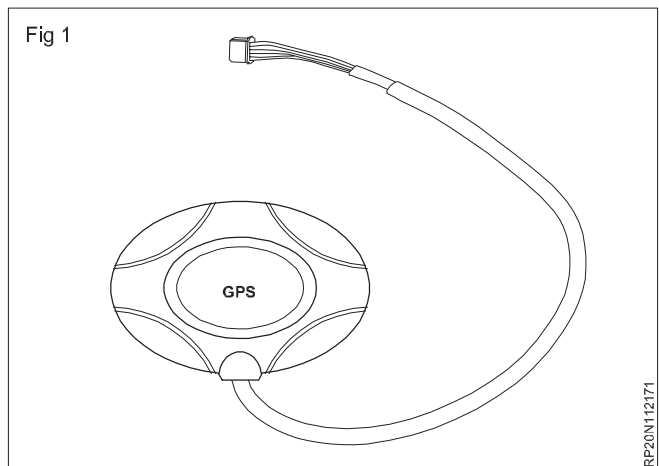

What are the benefits of a GPS on a drone?

Adding a GPS allows you to:

- 1 See your current speed (e.g., 60km/h)
- 2 See your distance from home (e.g., 1.1 KM)

- 3 Tells you the way home (arrow on your OSD)
- 4 See your current altitude (e.g., 100m)
- 5 Log your last GPS coordinates (e.g., before a crash)

Open source vs Closed source programming

Objectives: At the end of this lesson you shall be able to

- differentiate between open-source vs closed source programming.

Open-source software

- 1 Source code is open to all
- 2 Open-source software license promotes collaboration and sharing
- 3 Less costly
- 4 Less restriction on usability and modification of software
- 5 Big and active community enabling quick development and easy fixes
- 6 Supports through forums, informative blogs, and hiring experts
- 7 Immense flexibility as you can add features, and make changes, etc
- 8 Developers are ready to offer improvements hoping to get recognition
- 9 Can be easily installed into the computer
- 10 Fails and fixes fast

11 No one is accountable for any failures

Closed source software

- 1 Source code is closed/protected –Only those who created it can access it
- 2 Proprietary software license curbs rights
- 3 High-priced
- 4 More restrictions on usability and modification of software
- 5 Development and fixes depend on the discretion of creators
- 6 Dedication support
- 7 Limited flexibility (only as proposed by its creators)
- 8 Need to hire developers to integrate improvements
- 9 Needs valid license before Installation
- 10 Failure is out of the question
- 11 Responsibility for failure clearly rests on the vendor

Comparison of current FCs on the market

Objectives: At the end of this lesson you shall be able to

- compare existing FCs available in the market.

S. No	Name of FCs	Specification
1	KK 2.1.5	Input Voltage (V): 4.8-6.0V • Processor: Atmega • Auto Er- Yes • Receiver to Client - 1520us • Signal to ESC: 1520us • Gyro/Acc – Inven Sense Inc.
2	CC3D EVO Open-pilot Open Source 32 Bits Flight Controller	Model: Open Pilot CC3D EVO • Input voltage (V):5V Controller o Sensor: 3-AS Gyrometer, Accelerometer • Processor: Micro-controller STM32 • Sensor IC: MPU6000 • Micro-SD Card Note: No • Dimensions (mm) LWH: 40x40x18 mm • Weight (in ram) : 28 gram
3	APM 2.8	Specification: • Model: APM 2.8 • Power Supply: LP2985-3.3 • Port: MUX (UART0, UART2, mnnl2, and OSD are optional, OSD default output). • Input voltage: 12 -16V DC • Sensor: 3-AS Gyrometer, Accelerometer, Orientation Barometer • Processor: ATMEGA2560 and ATMEGA32U-2

Drone pilot (Junior) - Identify and compare the weather effects and analyze the performance of RPA

Introduction to measurement systems and sensors

Objectives: At the end of this lesson you shall be able to

- check Helicopter Measurement System and Sensor
- gain a basic understanding of the principals involved in the measurement
- access state-of-the-art sensors for a variety of engineering applications
- different types of sensors work in different ways
- brake specific weather properties to be obtained before applying
- describe the processor and platform
- interface for the processor with the RPA platform.

The measurement system is the organization of information flow in the system.

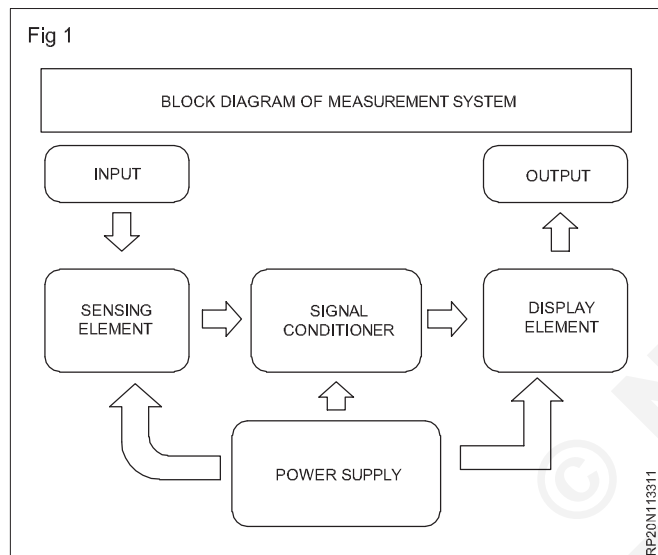

To develop a basic understanding of the principals involved in measurements.

Basic Requirement of Measurement :

- Must have the same margin as the standard measurement
- Standards to be used for comparison questions properly to be defined by and generally accepted
- Equipment used and methods used Verification

To introduce the state-of-the-art sensors for various engineering applications

What is the difference between different types of processor applications?

Different types of sensors for different engineering applications are classified on the basis of:

- 1 Electric flux or potential or magnetic or radio sensor
- 2 Humidity sensor
- 3 Fluid velocity or flow sensor
- 4 pressure sensors
- 5 Thermal or Heat or Temperature Sensor

6 Proximity sensors

7 Optical sensors

8 Position sensor

Operating principles, accuracy, measurement range, response time, portability, power consumption, connectivity and scalability, measurement range, data rates, power Commercially available in terms of consumption, market adoption and cost. Current state of the art sensors and monitoring equipment

Different types of sensors operate in very different ways.

Accelerometer	It measures the rate of change of the speed of the wind. The unit of measurement is meters per second squared or G (9.8 m/s).
Gyroscope	The rate of rotation of an object on its axis known as degrees per second or revolutions per minute (rpm) measured in
Inertial measurement unit (imu)	Precise measurement of radar orientation, velocity and location
Barometer	Pressure sensor that senses changes in air pressure
Magnetometer:distance	A compass to measure the magnetic field of the earth

Weather Sensor	Sensor Work
Weather Sensor	Amount of Rain
Rain Gauge	Air Temperature
Thermometer	Moisture Content
Hydrometer	Wind Direction
Air Vane	Wind Speed
Anemometer	Atmosphere Air Pressure
Barometer	Radiation
Pyranometer	Evaporation

Evaporator Pan	Evapotranspiration
----------------	--------------------

Weather Range	
Temperature Range	-40 to 65 °C
Temperature Accuracy	0.5 °C
Relative Humidity Range	0 to 100%
Relative Humidity Accuracy	±3%
Wind Speed Limit	1 to 60m/s
Wind Speed Accuracy	±5%
Wind Direction Limit	0 to 360°
Wind Direction Accuracy	±3°
Rain Fall Range	0 to 999.8 mm
Rain Fall Resolution	0.2 mm

Sensors and Platforms

Platform : the vehicle carrying the remote sensing device.

Sensor : the remote sensing device recording wavelengths of energy.

Ex. Aerial photography - the drone and the camera

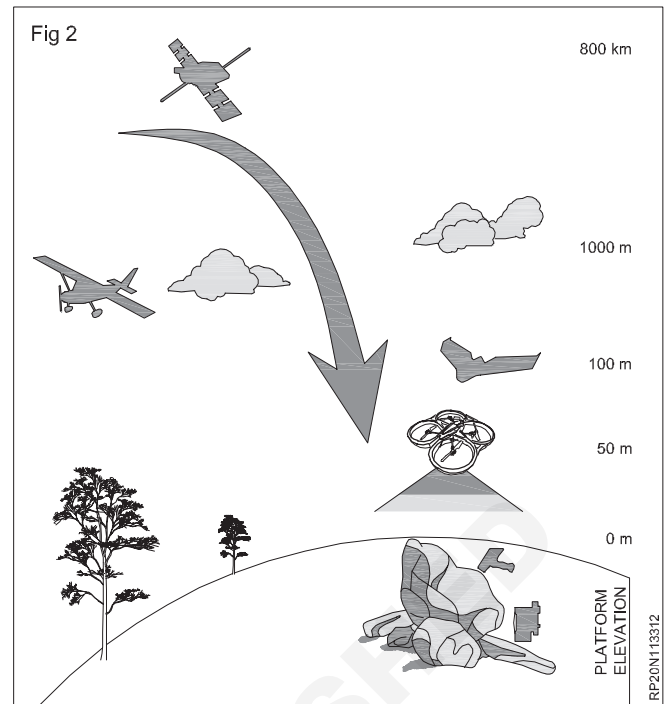

To enable the students to interface the sensors with RPA platforms.

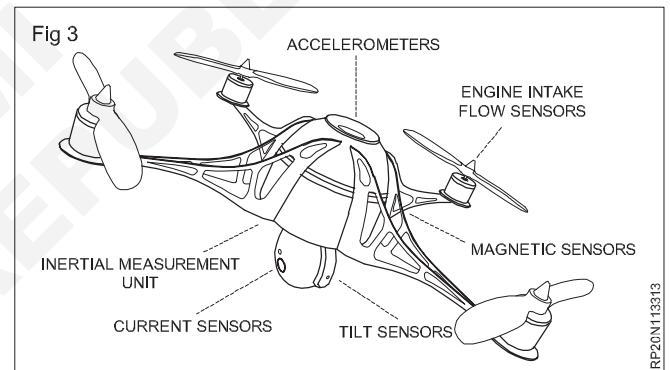

Drone pilot (Junior) - Perform installation, maintain and configuration of ground control station software

Introduction to telemetry

Objectives: At the end of this lesson you shall be able to

- get Telemetry
- describe data tracking
- state the mission plan
- get 3D mapping and modelling
- describe First-person-view (FPV) flight, safety and drone racing options.

Telemetry

Telemetry is the highly automated communications process by which measurements are made and other data collected at remote or inaccessible points and transmitted to receiving equipment for monitoring.

Drones generally include a radio frequency link that is used for telemetry and Ground Control Station communications. APM (the autopilot software) allows several ways of communication:

- Serial port, generally used together with a Telemetry Radio.
- UDP socket
- TCP socket



Fig 1

Data Tracking

The process for selecting specific metrics and events to track, then Collecting, arranging and analyzing the resultant data.

Mission planning

- Plot
- Upload
- Fly

Purpose

Operating your drone on a computer controlled, pre-programmed flight path is the easiest way to achieve consistent quality. Many drones offer on-deck flight programming, but these options allow even more control.

Features

- Waypoint missions and flight logging
- In-flight checks
- VR integration or 4K transmission

3D Mapping

Photogrammetry and orthomosaics for creating 3D maps. Orthomosaic is a combination of processes. Orthorectification or creating an orthophoto means adjusting the image for terrain relief, lens distortion and camera tilt so that it can be used for actual measurements. Mosaic combines multiple images into one.

The resulting maps are now highly accurate and can be used for various industrial applications such as civil engineering, surveying, urban planning and land management.

3D Modeling

Convert mapping into 3D modeling.

3D modeling can be used for commercial purposes like real estate; or, like the image at the top of the page, to create more informative maps. A more oblique shots, providing images of the facades. With those, modeling software can create realistic 3D models

First-person-view (FPV) flying, safety and drone racing options

First-person-view (FPV) flying

An FPV drone is an unmanned aerial vehicle (UAV) equipped with a camera that wirelessly transmits a video feed to glasses, headsets, mobile devices, or other displays. The user has a first-person view (FPV) of the environment the drone is flying in and can record video or still images.

- 1 Instructor take trainee on field with FPV drone.
- 2 Check all pre-flight procedure
- 3 Take an FPV goggle with an FOV of at least 35%, adjustable all resolution, glass optics and digital head tracking.
- 4 Fly FPV drone and practice.

Safety

- Make other trainee a 'visual observer' to ensure safety.
- Don't fly over people.
- Fly outside urban populated areas and at least 150 meters away from residential, commercial or industrial areas and not higher than 120 meters of altitude or check DGCA policy

Ground control station

Objectives: At the end of this lesson you shall be able to

- describe the surround control operation software
 - specify features.
-

What does the ground control station control?

A Ground Control Station (GCS) is a software application used to connect to a vehicle. This software allows users to adjust vehicle parameters and obtain real-time data during flight.

Mission Planner

Mission Planner is a ground control station for Plane, Copter and Rover.

Features

- Point-and-click waypoint/fence/rally point entry,

using Google Maps/Bing/Open Street maps/Custom WMS.

- Select mission commands from drop-down menus
- Download mission log files and analyze them
- Configure autopilot settings for RPA
- Interface with a PC flight simulator to create a full software-in-the-loop (SITL) UAV simulator.
- Run its own SITL simulation of many frames' types for all the ArduPilot vehicles.

Drone Data

Objectives: At the end of this lesson you shall be able to

- define RPA data
 - explain that there are types of data
 - describe the analysis and report on RPA data
 - obtain RPA imaging data
 - explain how to report on missions
 - explain how the data collected from these RPA images can then be measured, analyzed, tracked and can be compared over time.
-

What is the Drone data?

Drone data is a collection of hundreds or thousands of images from a single flight.

Image capture for viewing from an aggregated data set for Changed using software. These images Measured, analyzed, tracked and compared over time aggregated data from can be done

What are the types of drone data?

- 1 Flight data
- 2 Processor data
- 3 Overview data
- 4 Flight plan data
- 5 Asset data
- 6 Job data
- 7 Airports and weather data

How to Analyze and Report on Drone Data

To gain valuable data and insights from drone programs, select the right tools. A centralized mission planning and execution software is a great place to start that builds data in one place, making analysis easier over time.

Create reports in seconds on flight hours, pilot performance, drone assets and incident reporting with fully integrated drone software.

Drone Imaging Data

Images collected during missions can be processed in software to categorize, organize, and manage the data contained in the images. Image processing tools produce a final data set that can be easily analyzed, providing valuable business insights

If desired, a photogrammetric engine can also be used to transform the data into 2D or 3D maps, providing orthomosaic maps, digital surface models, or contour maps.

By storing and analyzing drone data for each mission, end users can easily make comparisons for specific time periods. Examples include the progress of a construction site, the amount of material stored at a particular location, or the gradual deterioration of wind turbine blades.

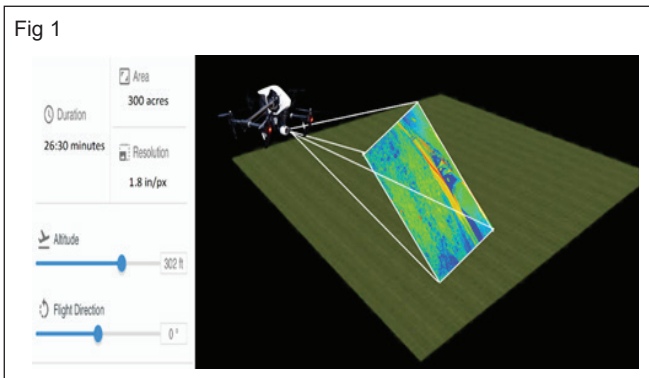

Data & Analytics: How to Report on Missions.

How to Report on Missions.

- Report export: CSV, PDF, charts, graphs, tables, etc.
- Platform analytics: including orders, missions, inspections, flights, pilots, and data performance figures

- Return on Investment: Track efficiencies, security benefits, and program outcomes.
- Data Mapping and Navigation: Use a graphical user interface to navigate 2D/3D models, visualize on maps, and click images.

The data collected from these RPA images can then be measured, analyzed, tracked, and compared over time.

Drone data can be manipulated for analysis

Data collected manually by inspectors ends up in photos and spreadsheets, but drone data can be quickly and easily manipulated and analyzed from multiple angles. For example, a single drone per mission can collect data that provides accurate shading conditions for solar sites at any time of the year.

In construction projects, drone data can be used to overlay images of actual construction progress onto site plans to assess whether construction is progressing to specifications.

Introduction to inspection procedures

Objectives: At the end of this lesson you shall be able to
 • **check Inspection Activities.**

Inspection procedure

Select and prepare

- 1 Select appropriate duty holders for inspection
- 2 Gather relevant information
- 3 Identify the objectives of the inspection
- 4 Select an appropriate inspection method
- 5 Make preparations for the inspection

Conduct intelligence led inspection

- 6 Make introductions
- 7 Assess specific risk control systems and the adequacy of health and safety management arrangements

8 Make regulatory decisions

9 Communicate the outcome and conclude the visit

Report, record, follow up, close out and evaluating

- 10 Reporting and recording
- 11 Following up and closing out
- 12 Evaluating

Knowledge about remote control

Objectives: At the end of this lesson you shall be able to
 • **tell me about the remote control**
 • **explain safety precautions, pre-flight checks**
 • **explain Arming and Disarming.**

PROCEDURE

Task 1 : Remotely-piloted aircraft system (RPAS) controls, know your remote control

Drones are normally flying with a transmitter or a remote controller. The remote controller consists joysticks and buttons that assist various functions

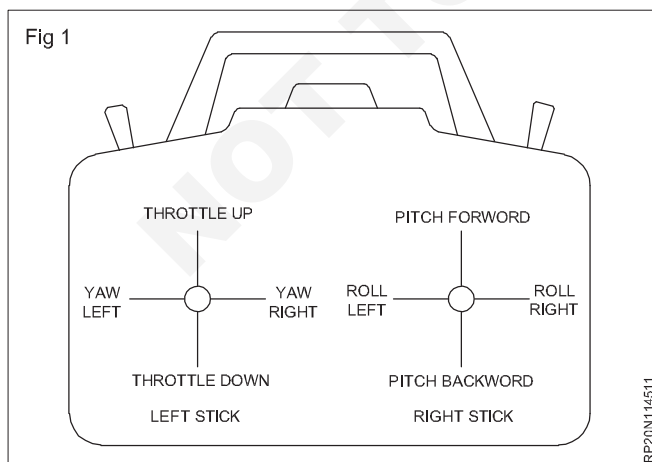

Right Stick: Roll & Pitch

The right stick consists roll (side to side) and pitches (forward and backward) movements of the drone.

Roll

The right stick moves left and right makes the drone roll left and right sides respectively around longitudinal axis without changing the drone's altitude or position.

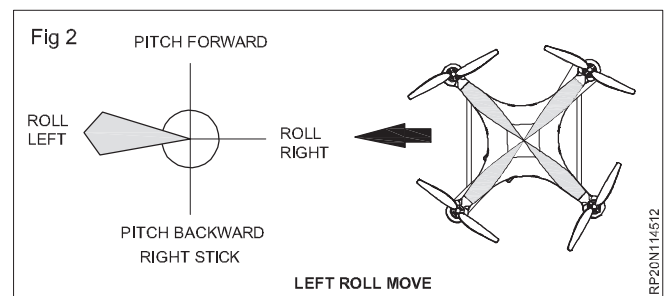

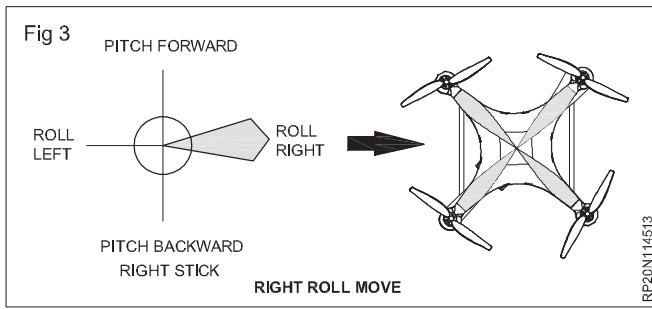

Pitch

The right stick moves up and down makes the drone pitch forward and backward sides respectively about a lateral axis.

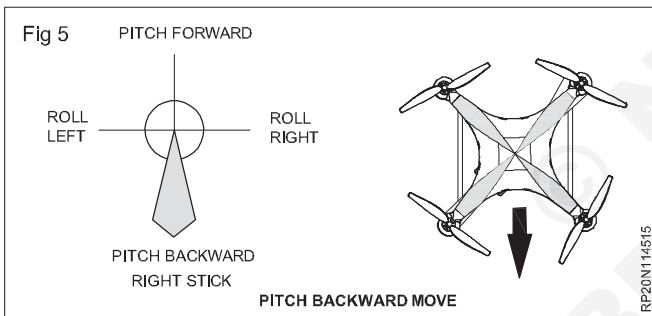
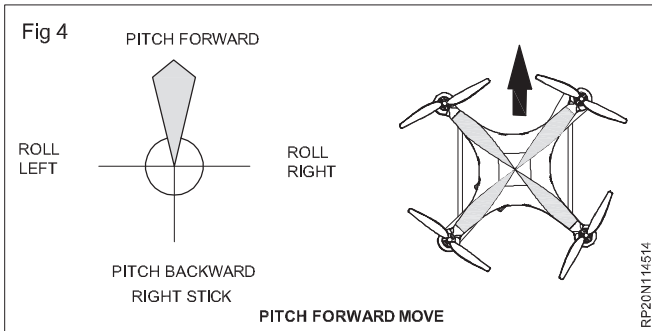

Left Stick: Yaw & Throttle

The left stick consists the yaw (rotation) and throttle (altitude) movements of the drone.

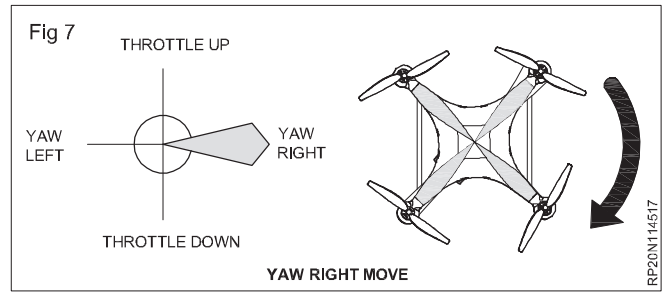
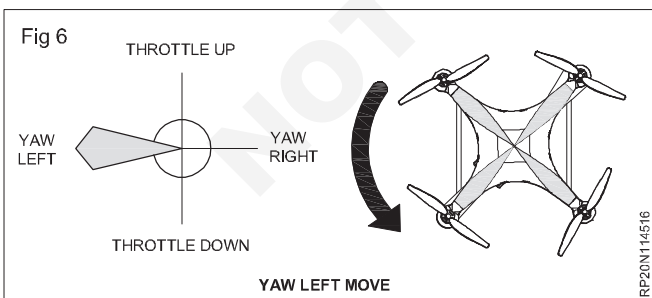

The left stick moves left and right makes the drone rotation clockwise or counter-clockwise respectively. This changes the drone nose into other directions without changes the drone current location.

Throttle

The left stick moves up and down makes the drone changes its altitude.

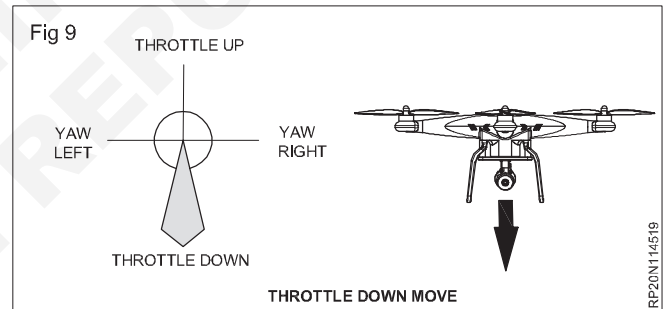
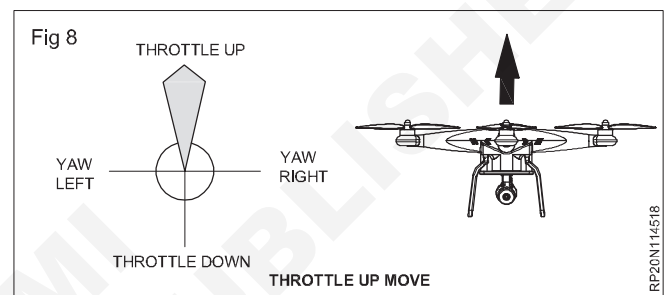

Drone safety essentials

- Do not fly above 400 feet.
- Never allow your drone to fly outside visual sightlines.
- Do not fly over groups of people, stadiums or within five miles of an airport.
- Never fly near emergency response sites.
- Do not fly near other aircraft.
- Never fly under the influence.

Pre-flight checks

- Check the flying conditions and the itinerary.
- Secure the necessary documentation before drone operation.

- Know and comply with specific drone operation laws in your area.
- Ensure if the drone is fit for flight.
- Always update your drone's firmware.

Arming

The drone will take-off and hover at an altitude of ten feet, to take off manually, move the left stick and right stick towards at the corner. Release both stick to its center location as you get the wanted altitude, and the drone will hover there.

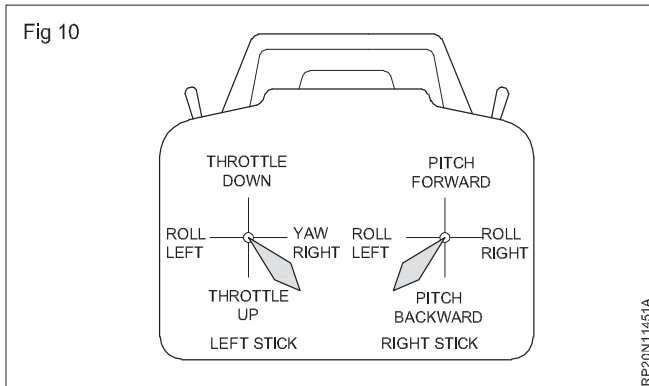

Disarming

Disarming is process to land drone and stop the running motors. Pull the throttle all the way down and hold for 5 seconds to turn the propeller motors off.

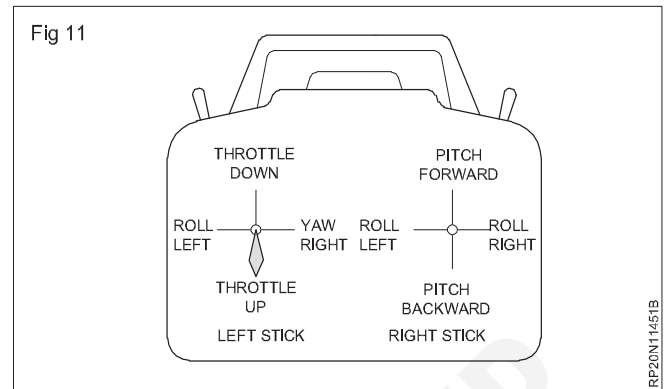

Procedures of Charging the battery

Objectives: At the end of this lesson you shall be able to

- describe the process of charging a battery
- describe RPA Storage Maintenance Resources and Standards.

Practice Batteries charging

Visually battery for inspect the outside body for any physical damage or bulging.

Once check manual by the battery manufacture pertaining to charging methods.

- 1 Connect battery adopter with charger and electricity plug
- 2 Connect the battery to the terminal of the charger: red is positive and black is negative. And JST wire of the battery.

When connecting the battery charger to the battery, you should consult the information regarding the appropriate charging conditions depending on the charger.

- 3 Switch "ON" electricity plug.
- 4 Use START/ENTER, DEC or INC key to set specific details fed into the battery from table 1.
- 5 The left side of the first line indicate the type of battery, left side of the second line indicates current.
- 6 After setting the current and voltage, press START/ENTER key for more than 3 second to start the process.



- 7 For change the values of parameters, please press START/ENTER key to make it blink and use DEC or INC to change the value. Then press START/ENTER key again to store the value.
- 8 Check on screen, "R" shows the number of cells detected by the charger and "S" is the number of cells set by you at previous screen.
- 9 If details correct press START/ENTER button, if not press BATT TYPE/STOP button to go back to previous screen to check number of cells of the battery pack.
- 10 Switch OFF the battery charger and disconnect the battery when fully charged.

	No.of Cells	Rated Voltage(V)	Maximum Charge Voltage (V)	Charge Current(A)
LiPo	1S	3.70	4.20	5.00
	2S	7.40	8.40	5.00
	3S	11.10	12.60	4.50
	4S	14.80	16.80	3.38
	5S	18.50	21.00	2.70
	6S	22.20	25.20	2.25

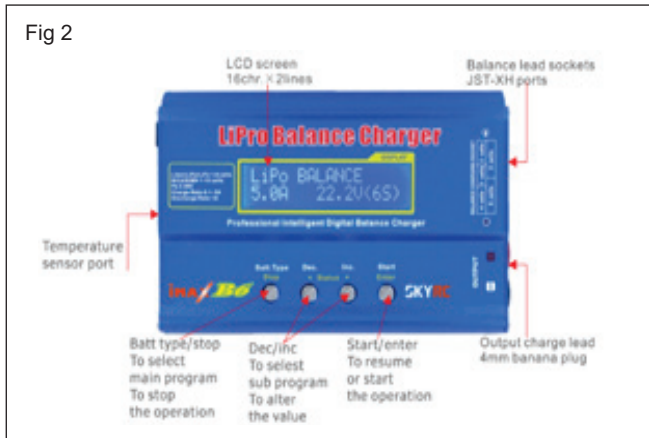

Avoid charging your battery beyond 100%

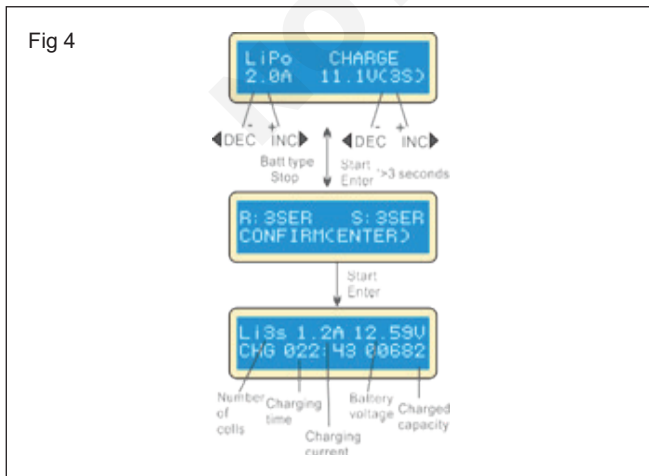

Importance of Cleaning the RPA Storage Maintenance resources and standards.

RPAs Maintenance Requirements

Maintenance and repair of RPAS shall be carried out in accordance with the manufacturer's approved procedures, as applicable.

Maintenance of the ground control equipment shall be carried out in accordance with the manufacturer's recommended inspection and overhaul interval, as applicable.

The remote pilot/ user shall not fly the RPA unless he/she is reasonably satisfied that all the control systems of RPA including the radio and Command & Control link are in working condition before the flight.

The UAOP holder shall maintain records of each RPA flight and make such records available to the DGCA on demand. Such records shall be maintained as per the format given in Annexure-X.

RPAs Maintenance Requirements

Besides maintaining and repairing RPAs as per manufacturer's approved procedures, a UAOP holder is also required to maintain records of each RPA flight as per format provided with CAR and make such records available to the DGCA on demand.

Equipment Requirements

All RPAs (except for Nano category intending to operate up to 50 feet (15 m) above ground level in uncontrolled airspace/ enclosed premises), are required to be equipped with specified serviceable components/ equipment. Indian Air Force will monitor movements of RPAs in the country in coordination with Airports Authority of India.

Identify Basic operating features of an RPA flight simulator

Objectives: At the end of this lesson you shall be able to

- mention the operational features of RPA Flight Simulator
- differentiate between different aircraft/RPAS and airfields
- explain Demo Flight.

Basic operating features of an RPA flight simulator

- Accurate flight model of drone
- Drone and pilot views
- Realistic scenarios
- Warnings for loss of VLOS and altitude restrictions
- Realistic lighting conditions
- Windows and Mac compatible
- High-end 3D graphics engine
- Real geological features and terrain.
- Able to run on older PCs due to basic level graphics, etc.
- Offers line-of-sight and FPV flight modes.
- Supports both acro mode and angle mode.
- Six pre-designed tracks or option to build your own.
- Customizable control responsiveness, drone weight, and camera speed.

- Drone flight simulator designed specifically for Multi-drone
- Good physics with a high degree of customizability for a life-like flight experience.
- A lot of preset quad options, with the freedom to adjust parameters to replicate your own quad.
- Preset tracks compel you to fly in and around obstacles.
- Customizable tracks give innumerable options of places and courses to fly.
- Multiplayer mode for fly.

How to select different aircraft/RPAS and aerodromes

Select the different aircraft/drones

- 1 See properly different aircraft/drones from Fig 1.
- 2 Based on payload, endurance and range select the aircraft.

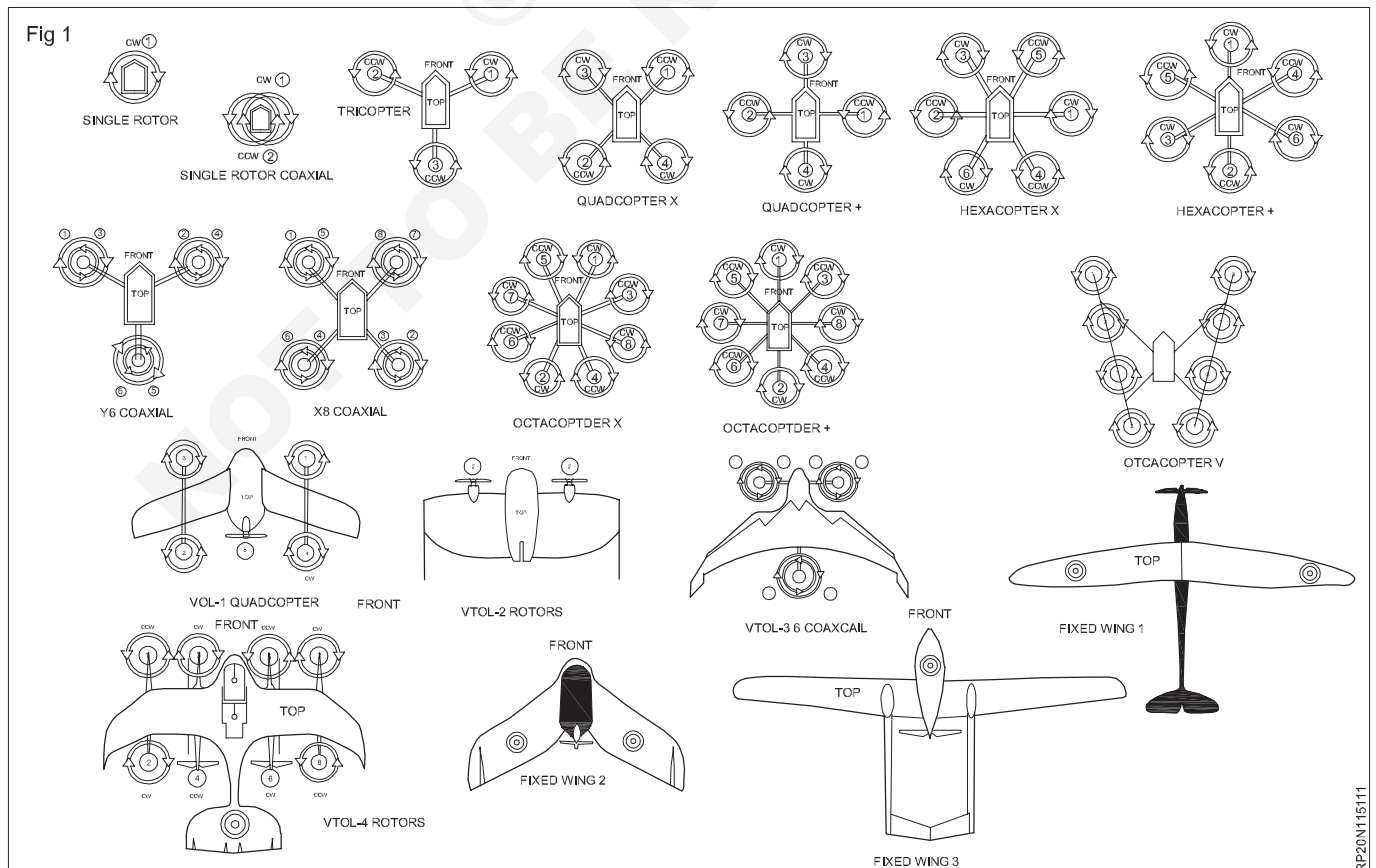

Knowledge of Demo flight.

A demo flight is the best way to practice and understand drone flight. Practical training will include RPA in live component flight, and/or simulated flight training, which will include demonstrating the control of the RPA in its operating conditions, including safe recovery during emergencies and system failures.

Trainee can observe these following things:

- An introduction on how a drone fly

- how to use its remote controller
- practice with all flight modes take-off, Taxiing, cruise, landing the drone
- Basic manoeuvres in the air
- Experience about emergency handling

Introduction to demonstrate solo flight training and Live RPA flying

Objectives: At the end of this lesson you shall be able to

- the description of Solo Flight Teaching and Live RPA Flying
 - describe the flight operation
 - get Flying A RPA in Simulator Training, visit solo flight training and live RPA flight.
-

Demonstrate solo flight training and Live RPA flying

- 1 Proper flight preparation procedures, including pre-flight planning and preparation, powerplant operation, and drone systems
- 2 Taxiing or surface operations, including runups
- 3 Take-offs and landings, including normal and crosswind
- 4 Straight and level flight, and turns in both directions
- 5 Climbs and climbing turns
- 6 Airport traffic patterns, including entry and departure procedures
- 7 Collision avoidance, windshear avoidance, and wake turbulence avoidance
- 8 Descents with and without turns
- 9 Flight at various airspeeds
- 10 Emergency procedures and equipment malfunctions
- 11 Ground reference maneuvers

- 12 Approaches to the landing area
- 13 Hovering and hovering turns
- 14 Go-arounds
- 15 Simulated emergency procedures, including autorotational descents with a power recovery and power recovery to a hover
- 16 Rapid decelerations
- 17 Simulated drone-inoperative approaches and landings

Flight Operations : These including dispatch, flight planning, flight watch, weather data provision, operations control, ground to air communications and integration with payload, schedules and maintenance planning, ATC and airport management can also be covered.

Practice RPA flying in Simulator

- 1 Trainee connect the simulator
- 2 Practice flying in simulator

Introduction to photogrammetry for stitching and analysis of RPA pictures

Objectives: At the end of this lesson you shall be able to

- describe Photogrammetry for stretching
 - get analysis of RPA images.
-

Photogrammetry is the practice of stitching 2D images from multiple angles into a 3D object

Photogrammetry can be used to make:

Highly accurate and realistically photo textured models of buildings, archaeological sites, landscapes (if the images are taken from the air) and objects.

Drone image analysis procedure.

- a Take original picture at 35 m above the ground,
- b Image cropped to retain nine central mats from a plot,
- c HSB threshold selection for green pixels and
- d Filtered image with only green pixels selected shown in red.

Drone pilot (Junior) - Plan and organize training to fly RPA in controlled environments

Introduction to demonstrate RPA flying operation

Objectives: At the end of this lesson you shall be able to

- check out RPA Flight Operations
- describe the different modes of operation
- calculate free trade code parts
- describe a place to learn how to fly an RPA
- explain how to get your RPA off the ground
- explain how your broadband is flying left/right and forward/backward
- explore early and advanced RPA flight techniques.

Normal drones are controlled in this "mode 2".

Use two sticks to control the drone. The following tasks are assigned to the front, back, left and right operations of each stick.

Tilt the right stick back or forward to go back and forth (pitch), tilt the left stick down or up (throttle) to move back and forth (pitch), tilt left and right to turn yaw (roll), and left and right Tilt left and right to move (ailerons).

Flying a RPA in controlled environment with different modes of operation.

MANUAL	The operator pilot has full control over the platform.
TAKE-OFF	The autopilot will execute the takeoff maneuver to make the platform go from the ground to flying in the air.
AUTO	AUTO mode executes the programmed Flight Plan (FP) based on waypoints.
NAV-TO	The autopilot flies to the specified coordinates, maintaining current altitude and airspeed.
LOITER	For Fixed Wing Platforms only. The autopilot will follow a circular pattern around the location where LOITER mode is engaged.
HOVER	For Rotary Wing Platforms only. The autopilot will maintain position, heading and altitude once HOVER mode is engaged and the platform is stopped.
EMERGENCY	For Rotary Wing Platforms only. EMERGENCY mode may not be commanded directly by the operator and is the result of a failure in Magnetometer and/or GPS while being in any other operation mode.
SAFE	The autopilot will command the aircraft to fly to a previously set Safety Altitude. Once achieved, it will automatically switch to LAND mode.
DIRECTED	The autopilot maintains current IAS, altitude and heading.
LAND	The autopilot executes the land maneuver, from its current flight mode to a predefined and even relative landing site.
ASSISTED MANUAL	The operator is able to over-command directly from the joystick/gamepad.

Main Quad Copter Parts Overview

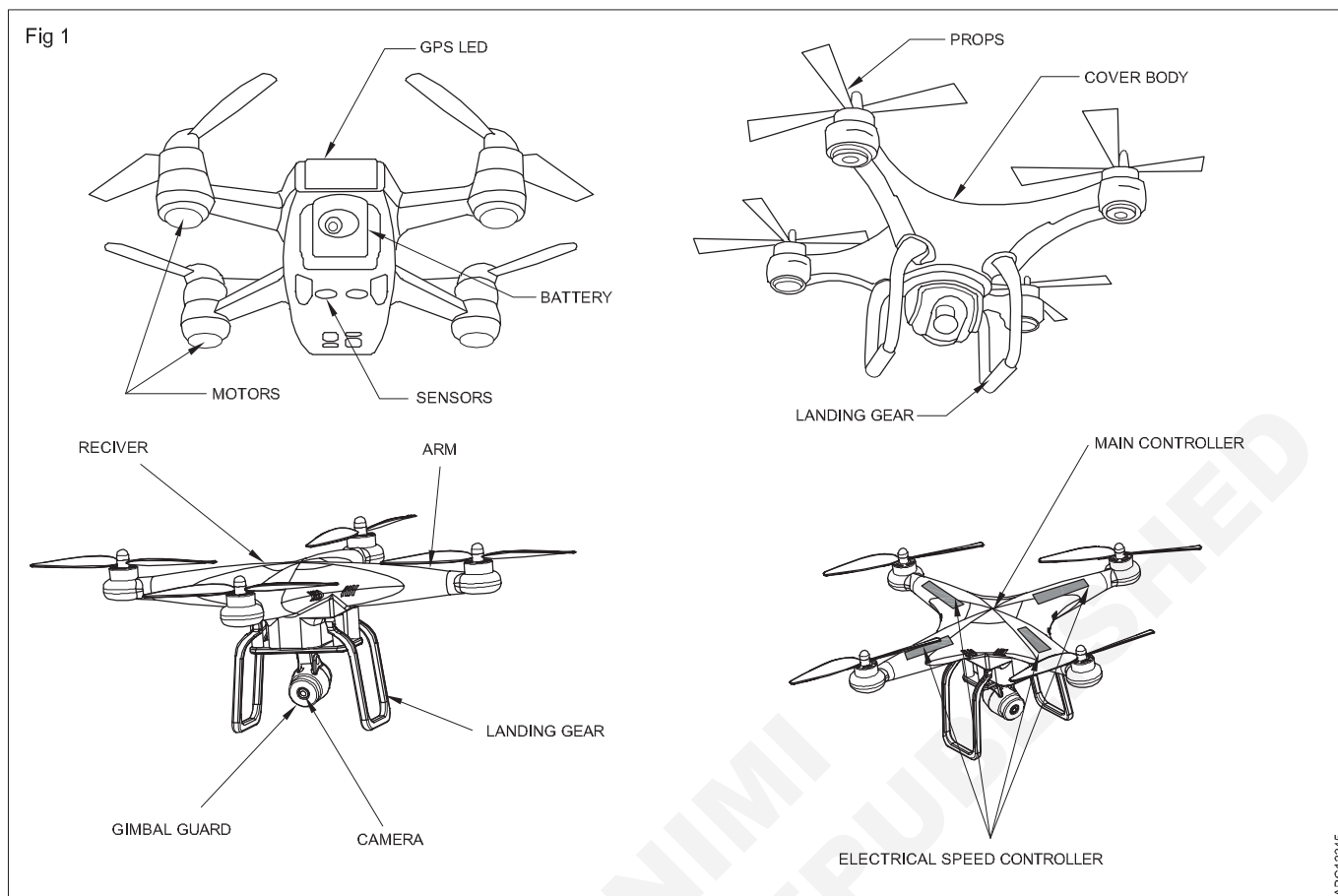

Choosing a place to learn how to fly an RPA

Follow these steps when selecting locations to fly drone

- Make sure location should be in legal to fly as per DGCA regulations.
- Understand the airspace of the location.
- Check for local regulations to fly.
- Stay away from people or animals.
- Avoid windy conditions.
- learn on grassy ground.
- Choose a safe, and visually interesting location to fly your drone.

How to get your RPA off the ground,

Getting your drone off the ground

- Use the throttle stick to fly the drone into the air.
- Push the throttle stick (left stick) up very slowly to spin the propeller. Then stop.

- Repeat this several times until you get used to the sensitivity of the throttle.
- Press the throttle more slowly than before until the drone lifts off the ground. Then return the throttle stick to zero to land the drone.

Flying your quad copter left/right and forwards/backwards

- First, hover the drone.
- Push the right stick forward to fly forward a few feet.
- Pull the right stick back to its original position.
- Then walk back a few meters and return to starting position.
- Push the right stick left to move the drone a few feet to the left.
- Return to starting position and fly a few feet to the right.
- Once it starts to rotate (yaw), move the left stick left or right to point the drone in the same direction.

Draw left/right pattern using the roll control.

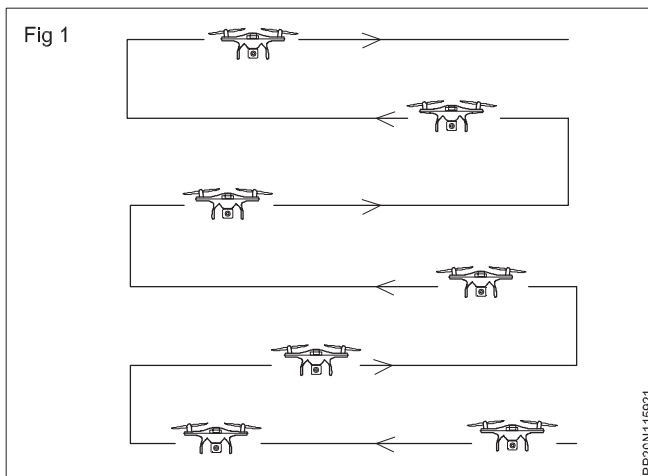

Draw forward/backward motion pattern using the pitch control

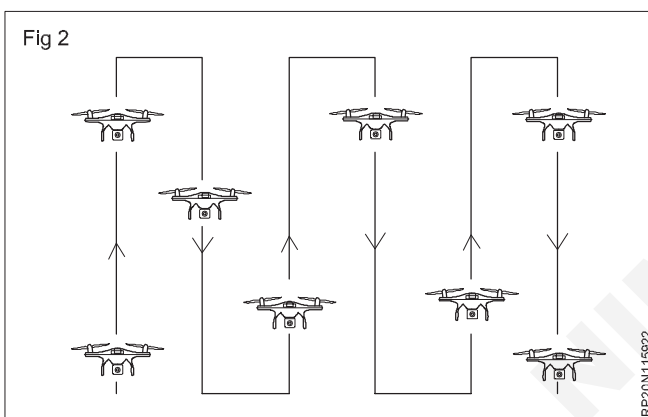

Beginner and Advanced RPA flying techniques.

Beginner RPA flying techniques

- 1 Read the instructions first
- 2 Charge your quadcopter battery
- 3 Quadcopter Positioning
- 4 Push the quadcopter throttle down
- 5 Take off and land
- 6 Take off and hold quadcopter position
- 7 Rotate the quadcopter
- 8 Create a mental image
- 9 Getting to know quadcopter controls
- 10 Combine quadcopter controls
- 11 Keep the drone close
- 12 Take care of your quadcopter

Advanced RPA flying techniques

- 1 Fly in a different pattern. For this you will need to fly the drone from the front the entire time..
- 2 Bank turns (A consistent circular turn in a clockwise or counterclockwise direction.) Keep a slight forward pitch for forward motion. Apply throttle, and roll the drone in the direction of the turn (left or right).

Introduction to Payload considerations

Objectives: At the end of this lesson you shall be able to

- describe payload considerations.
- get camera options, narrow, still photography, video photography, GPS mode, vibrate and jello effect,
- get exposure settings, camera lens, video frame rate, image file, camera payload and other payload possibilities.

Payload calculation

Formula to calculate Payload

$$\text{Payload} = \text{AUW} - \text{Drone Weight}$$

Use the formula and calculate other payload possibility which drone can carry.

S.No.	AUW	Drone Weight	Payload
1	4 kg	3kg	1kg
2	5 kg	3kg	2kg
3	6 kg	4kg	2kg
4	8 kg	5 kg	3 kg

Jello effects

Wobble. This phenomenon [also known as Jello effect. Appears when the camera is vibrating, in situation such as band- held shots at telephoto settings, on when

shooting from a moving vehicle. The rolling shutter causes the image to wobble un naturally.

Camera Resolution

The camera resolution definition is basically the total amount of pixels captured. It is also called the "Number of Recorded Pixels" by the CIPA DCG-001 (an organization based in Japan that handles photography-based technology).

Exposure settings

Aperture - How wide your lens is. The wider your aperture, the lighter is let in. ...

Shutter speed - How quickly your shutter opens and closes. Fast shutter speeds let in less light.

ISO - Your camera's sensitivity to light.

Camera lenses

- Wide Angle

- Standard
- Short Telephoto
- Telephoto
- Focal Length

Frame rate

Base or project frame rate is the frame rate your camera records to produce 100% realistic speed. The standard is 24fps for movies, 30fps for TV/ broadcast and for PAL broadcast, it's 25fps.

Camera payloads

Camera payload is the camera weight a drone carries.

Other payload possibilities

© NIMI
NOT TO BE REPUBLISHED

Drone pilot (Junior) - Perform and obtain training to fly RPA in uncontrolled airspace including VLOS and BVLOS flight

What are VLOS, BVLOS, IFR, and VFR?

Objectives: At the end of this lesson you shall be able to

- specify VLOS, BVLOS, IFR, and VFR
- explain how they affect RPA operations
- find out the terms and restrictions regarding VLOS and BVLOS.

VLOS, BVLOS, IFR, and VFR

1 The RPAS Operating condition (VLOS, or BVLOS)

2 The meteorological minimum conditions (VMC, or IMC)

3 The flight rules (VFR, or IFR)

VLOS	RPAS Operating Condition	Explain how surveillance trajectories and obstacles and drones are contended with
BLOS		
VFR	Flight Rules	Explain operated drones including ATC, weather minima, airspace interaction, flight planning, etc.
IFR		

They affect RPA operations

VLOS, or BVLOS depending on monitoring trajectory and de-confliction with obstacles and air traffic.

VLOS use for the pilot to directly operate the drone and “sense and avoid” collision with obstacles.

Beyond Visual Line of Sight operations, BVLOS, do not use direct operate the drone and surrounding airspace for monitoring and sense and avoid, so alternate means must be present.

The flight rules (VFR or IFR) determine how the aircraft is operated including flight planning, interactions with airspace and air traffic control. There are also increased pilot training /knowledge requirements, and equipment/system capability requirements associated with operations under instrument flight rules.

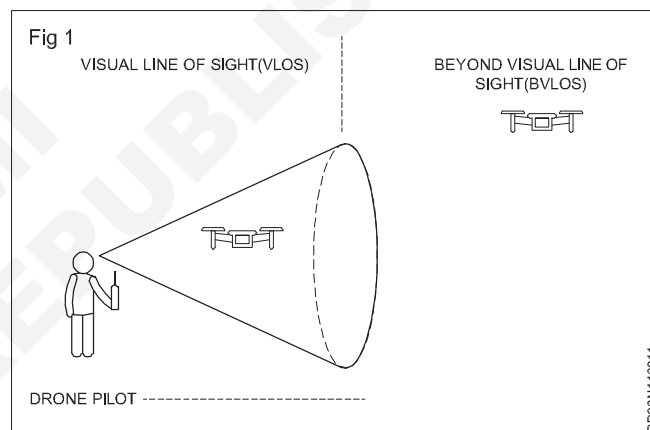

Flights performed in ‘visual line of sight’ (VLOS)

Generally, 450m (unaided) in Visual Meteorological Conditions (VMC) with a minimum ground visibility of 5 km. beyond visual line of sight’ (BVLOS)

Introduction of different payload like cameras, thermal cameras, Lidar sensor, RGB and Hyper spectral cameras

Objectives: At the end of this lesson you shall be able to

- describe the different payloads such as camera, thermal camera, lidar sensor, RGB and hyperreal cameras.
- describe the payload connection.
- achieve its operating procedure for RPA flight in uncontrolled environments.
- achieve RPA on application basis in various sectors like Agriculture, Inspection and etc.,

LIDAR

Light Detection and Ranging (LiDAR) sensors use laser emitted light energy to scan the ground and measure the ranges of what bounces back. The end result is a rich set of elevation data that can be used to produce high-resolution maps and 3D models of natural and man-made objects.

Hyperspectral

"Hyperspectral sensors are like a scalpel that allows you to dissect exactly what is happening within very narrow bands of spectral content. Multispectral sensors are a broad sword that collects less intensive spectral data," shared Jason San Souci, GISP.

Thermal

Thermal sensors measure the relative surface temperature of land and objects beyond the scope of human vision and create aerial thermal imaging for analysis and reporting. “Thermal images show differences in total radiant energy allowing for temperature calculations. To determine true temperature, you’ll need to use a calibrated radiometric sensor,” shared Scott Hatcher, a Geospatial Scientist.

Hyperspectral

“Hyperspectral sensors are like a scalpel that allows you to dissect exactly what is happening within very narrow bands of spectral content. Multispectral sensors are a broad sword that collects less intensive spectral data,” shared Jason San Souci, GISP.

Multispectral

Multispectral sensors are used to capture near-infrared radiation (NIR) and ultraviolet light invisible to the human eye.

Multispectral sensors fall into two categories: modified and multiband. Modified sensors are created when a special filter is placed on a standard visual sensor. As a result, modified sensors collect several—typically 3-5—bands of light at once. Each band is collected by a dedicated sensor so there is no need for multiple flights. Multiband sensors also enable you to mix different band combinations to meet your needs.

Thermal

Thermal sensors measure the relative surface temperature of land and objects beyond the scope of human vision and create aerial thermal imaging for analysis and reporting. “Thermal images show differences in total radiant energy allowing for temperature calculations. To determine true temperature, you’ll need to use a calibrated radiometric sensor,” shared Scott Hatcher, a Geospatial Scientist.

RPA Flight in an uncontrolled environment.

Uncontrolled airspace is airspace where an Air Traffic Control (ATC) service is not necessary or cannot be provided for practical reasons.

RPA Operators [except nano class who intend to operate in uncontrolled airspace/enclosed premises 50 ft (15 m) above ground level.

Micro RPA operating below 200 ft (60 m) above ground level in uncontrolled airspace/enclosed premises. However, the user shall notify the local police office 24 hours prior to the conduct of the actual operation.

Drones are classified based on several criteria. It can be range based, endurance based, payload based etc.

Drone pilot (Junior) - Apply emergency protocols to control and manage RPA flight

Apply emergency protocols to control and manage RPA flight

Objectives: At the end of this lesson you shall be able to

- **get Security Risks Guidelines for Flying RPA**
- **define UAV regulations in India,**
- **tell us about road safety, UAV operation and safety**
- **describe the regulator and regulations,**
- **define emergency detection and handling, loss of link in flight emergency, fly-away, loss of power, Control surface failure.**

List of safety precautions drone operators should consider

- Do not fly above 400 feet
- Never allow your drone to fly outside visual sightlines
- Do not fly over groups of people, stadiums or within five miles of an airport
- Never fly near emergency response sites
- Do not fly near other aircraft
- Never fly under the influence

UAV Regulations in India

No person shall operate an unmanned aircraft system without first registering on the Digital Sky Platform and obtaining a Unique Identification Number, unless exempted from the requirement of a Unique Identification Number under these Rules.

The registration record of all unmanned aircraft systems to which a Unique Identification Number has been issued under these rules shall be maintained by the Director General..

It shall be the responsibility of the person operating an unmanned aircraft system to ensure that such unmanned aircraft system conforms to a valid type certificate.

Personal Safety,

- Drone safety essentials
- Do not fly above 400 feet.
- Never allow your drone to fly outside visual sightlines.
- Do not fly over groups of people, stadiums or within five miles of an airport.
- Never fly near emergency response sites.
- Do not fly near other aircraft.
- Never fly under the influence.

UAV Operations & Safety

- 1 Check Regulations
- 2 Determine the Right Environment

- 3 Take an Insurance Cover Your Drone
- 4 Practice
- 5 Ensure Your Battery Is Fully Charged Before Flying It
- 6 Inspect Your Drone Before Flying
- 7 Calibrate the Compass
- 8 Ensure Your Drone Achieves a GPS Lock Before Flying
- 9 Respect others' privacy

Demonstrate Handling Inflight emergencies

ACTION IF DRONE FLY AWAY

MAINTAIN Visual Contact with Aircraft

CONTACT ATC via two way Radio

VERIFY Remote controller power is ON

Check GPS activate or not

IF UNABLE TO RE-ESTABLISH LINK

CONTINUE to maintain Visual of aircraft

UPDATE ATC with the drone position

ACTION IF DRONE LOSS OF GPS

If GPS signal is lost in flight "RTH band intelligent flight mode will not be functional"

IF UA IS FLYING ERRATICALLY BUT STILL LINKED

Switched to "A" or ATTI mode to disable GPS

Pilot the UA to a safe landing area aircraft

Perform a manual landing and shut down

ACTION IF DRONE BATTERY INDICATES LOW

Maintain visual contact with aircraft

IMMEDIATELY return drone to you for landing

IF DIS ORIENTED

USE "HOME LOCK" to bring aircraft back for landing

IF STRONG WINDS PREVENT RETURN FLIGHT

USE camera to locate suitable divert location

LAND drone